



Investigation of fire emissions from Li-ion batteries

Petra Andersson, Per Blomqvist, Anders Lorén and Fredrik Larsson

SP Technical Research Institute of Sweden

Investigation of fire emissions from Li-ion batteries

Petra Andersson, Per Blomqvist, Anders Lorén and
Fredrik Larsson

Abstract

Investigation of fire emissions from Li-ion batteries

This report presents an investigation on gases emitted during Lithium-ion battery fires. Details of the calibration of an FTIR instrument to measure HF, POF_3 and PF_5 gases are provided as background to the minimum detection limits for each species. The use of FTIR in tests has been verified by repeating experiments reported in the literature. The study reports on gases emitted both after evaporation and after ignition of the electrolyte fumes. Tests were conducted where electrolyte is injected into a propane flame and the influence of the addition of water is studied. Finally three types of battery cells were burnt and emission of fluorine and/or phosphorous containing species quantified.

Key words: Lithium-ion battery fires, toxic gases, FTIR

SP Sveriges Tekniska Forskningsinstitut
SP Technical Research Institute of Sweden

SP Report 2013:15
ISBN 978-91-87461-00-2
ISSN 0284-5172
Borås 2013

Contents

Abstract	3
Contents	4
Förord / Preface	6
Sammanfattning / Summary	7
1 Introduction	8
2 FTIR instrumentation	10
3 Fundamental Chemistry of LiPF₆	12
4 Pre-study of fluorinated emission products	13
4.1 Production of calibration gases	13
4.2 Calibration of FTIR	13
4.2.1 HF	13
4.2.2 PO ₂ F ₃	14
4.2.3 PF ₅	15
4.3 Stability of PO ₂ F ₃	18
4.3.1 Room temperature	18
4.3.2 Elevated temperature	19
4.4 Heating tests with the Cone Calorimeter	19
4.4.1 Evaporation tests of pure components	20
4.4.2 Evaporation tests with mixtures of components	22
4.4.3 Combustion tests	23
5 Burner tests with electrolyte	26
5.1 Electrolyte – salt solutions	27
5.2 Tests conducted	27
5.3 Test Results	29
6 Fire tests with batteries	48
6.1 Batteries tested	48
6.1.1 Cell preparation	49
6.2 Experimental apparatus	49
6.3 Experimental procedure	51
6.4 Results	51
6.4.1 Video	51
6.4.2 HRR and gas measurements	55
6.5 Discussion	62
7 Conclusions	64
8 References	65
Appendix A Tests conducted in burner	A1
Appendix B Results from battery cell tests	B1
Appendix C Photos from cell experiments	C1

Förord / Preface

This work has been sponsored by Brandforsk, Brandforsk project number 402-111 and FFI project number 35755-1 which is gratefully acknowledged.

Several persons have contributed to the work including technical staff at Fire technology, Sven Ove Vendel and Brith Månsson.

Input from the reference group consisting of Ulf Lundström, Trafikverket, Thomas Mohlen, Scania, Bengt-Erik Mellander, Chalmers and Patrik Roth, Atlas Copco is also acknowledged.

Sammanfattning

Rapporten beskriver tests som har gjorts på elektrolyt i Litium-jon batterier. Elektrolyten blandades till baserat på litteraturdata och injicerades i en propanflamma. Olika blandningsförhållanden användes och även vatten sprutades in. Gaser från branden samlades in och analyserades med hjälp av en FTIR. Projektet inleddes med att FTIRen kalibrerades upp för att kunna mäta HF, POF₃ och PF₅.

Försöken visade att det var möjligt att använda FTIR för att mäta dessa gaser. Dock visade det sig i ett tidigt skede av projektet att PF₅ är så pass reaktiv att den inte finns tillräckligt länge för att detekteras. Däremot visade sig POF₃ finnas med i samtliga försök. POF₃ är en gas som potentiellt är mycket giftig, eventuellt giftigare än HF. Influensen av vatten som sprutades in i flammorna med avseende på emitterade gaser undersöktes. Det gick dock inte att påvisa någon effekt på vilka gaser som emitteras av att spruta in vatten.

Projektet avslutades med att battericeller som kan finnas i elhybrider eldades och gaserna analyserades. I dessa försök mättes HF men ingen POF₃. Detta berodde dock sannolikt på att vi hamnade under detektionsgränsen för POF₃ i dessa försöken.

Samtliga resultat extrapoleras och jämfördes med rapporterade emissionsdata från mätningar gjord på en helbilsbrand. Extrapolationen gav värden i samma storleksordning som de storskaliga bränderna.

1 Introduction

Batteries are used in more and more applications and are seen as an important solution to meet the climate goals for the automotive sector. Several types of batteries are used today and more are developed over time.

One of the most common types of batteries today is lithium-ion (Li-ion) batteries due to their high energy and power densities. Li-ion also offers long life time. Li-ion batteries have, however, some safety drawbacks. Compared to many other battery technologies, Li-ion batteries have a smaller region of stability, regarding temperatures and cell voltage. Li-ion batteries can undergo a thermal runaway resulting in gassing and fire, and potentially even explosion. A thermal runaway can be the result if a Li-ion cell is exposed to increased temperatures, typically starting from 120-150 °C. Other types of abusive conditions, e.g. overcharge or deformation can also result in venting of gasses and thermal runaway reactions. The Li-ion cell has an organic based electrolyte which enables its high energy and power densities, but it is also flammable.

Another feature of Li-ion batteries is the potential for emitting toxic gases. So far it is HF (Hydrogen Fluoride) that has gained most interest as this is a very toxic gas. Other gases that can pose a danger include the chemical species in the oxidation and thermal breakdown of the initial LiPF_6 salt solution. Most likely PF_5 , POF_3 and HF are of greatest concern but also the fluorinated phosphoric acids can be of interest since they will give HF and phosphoric acid when completely reacted with water. The toxicity of all these gases is not fully established. The Swedish Work Environment Authority has exposure limits for total fluorides, HF and phosphoric acid but lacks data for the rest of the substances¹.

The NGVⁱ for total fluorides are 2 mg/m³ and HF has a TGVⁱⁱ of 2 ppm. NIOSH (National Institute for Occupational Safety and Health, USA) states that HF has a IDLH (Immediately Dangerous to Life and health) value of 30 ppm. No exposure limits are given for PF_5 and POF_3 , however their chlorine analogues, PCl_5 and POCl_3 have NGV values of 0.1 ppm. The toxicity might, however, differ between the chlorine and fluorine species and there is no general rule like “fluorine is always more toxic”. But, still, the limits are low and gases evolved from battery fires are certainly of great concern to both the fire fighters, people in the vehicles and in the close vicinity of the fire. Both of these gases are very reactive and very few measurements have been performed on these gases in the literature. Yang, Zhuang and Ross² report measurements conducted using TGA (Thermal Gravimetry Analysis) and FTIR (Fourier transform Infra Red) on pure LiPF_6 salt and salt solved in EC, PC, DMC and EMC but so far little or none work has been published on emissions of these gases from fire scenarios.

One important aspect for Li-ion batteries is the possibility to extinguish a fire in them. Several different types of advice are available such as using copious amounts of water or sand or letting the battery burn. There are, however, several situations when it is not possible to allow a battery fire to continue, e.g. if someone is trapped in a car. It is, therefore, important to investigate different extinguishing means together with the toxic gases emitted during extinguishment.

The work presented in this report includes calibration of an FTIR equipment to be used to measure HF, POF_3 and PF_5 to analyse smoke from fire tests. The technique developed is

ⁱ ”Nivågränsvärde” Mean value threshold in a working environment

ⁱⁱ ”Takgränsvärde” Maximum allowed concentration in a working environment

then used in different heating and combustion conditions in different scales. The impact of water on the combustion gases is also investigated.

2 FTIR instrumentation

The instrument used for analysis of the emission products in the fire tests reported here was an FTIR spectrometer. Fourier transform infrared spectroscopy (FTIR) is a general technique used to obtain an infrared spectrum of absorption from a solid, liquid or gas. An FTIR spectrophotometer uses an interferometer to simultaneously collect spectral data over a wide spectral range, in the form of an interferogram, which is different from classical dispersive spectroscopy, which sequentially collects data at each wavelength. A Fourier transform is a mathematical algorithm used to convert the raw data into a spectrum, corresponding to the spectrum resulting from a classical scanning dispersive spectrometer. The use of an interferometer gives two main advantages in comparison with the traditional dispersive spectroscopy: First, all wavelengths are collected in principal simultaneously. Second, the interferometer throughput is higher compared to dispersive methods which gives a higher signal.

The measurement system used here consisted of an FTIR spectrometer, a gas cell, sampling lines, filters for removing particulates before the gas cell and a pump that continuously drew sample gas through the cell. The system is specified in Table 1.

Table 1 Specification of the FTIR measurement system.

Instrumentation	Specification
Spectrometer	Thermo Scientific Antaris IGS analyzer (Nicolet)
Spectrometer parameters	Resolution: 0.5 cm ⁻¹ Spectral range: 4800 cm ⁻¹ – 650 cm ⁻¹ * Scans/spectrum: 10 Time/spectrum: 12 seconds Detector: MCT
Gas cell	Volume: 0.2 litres Path length: 2.0 m Temperature: 180°C** Cell pressure: 650 Torr**
Primary filter	M&C ceramic filter heated to 180 °C
Secondary filter	M&C sintered steel filter heated to 180°C***
Sampling tubing	4/6 mm diameter PTFE tubing heated to 180°C. The length of the tubing was 1.5 m in the Cone calorimeter tests and 8.5 m in the battery tests.
Pump	Sampling flow: 3.5 l/min

* The spectral range used in the initial pre-study was 4000 cm⁻¹ – 650 cm⁻¹.

** In the initial pre-study and calibration the cell temperature was 170 °C and the pressure was ~740 Torr.

*** A 37 mm diameter planar filter (PTFE) heated to 130°C was used in the initial pre-study.

Photos of the FTIR measurement system connected to the Cone calorimeter are shown in Figure 1.

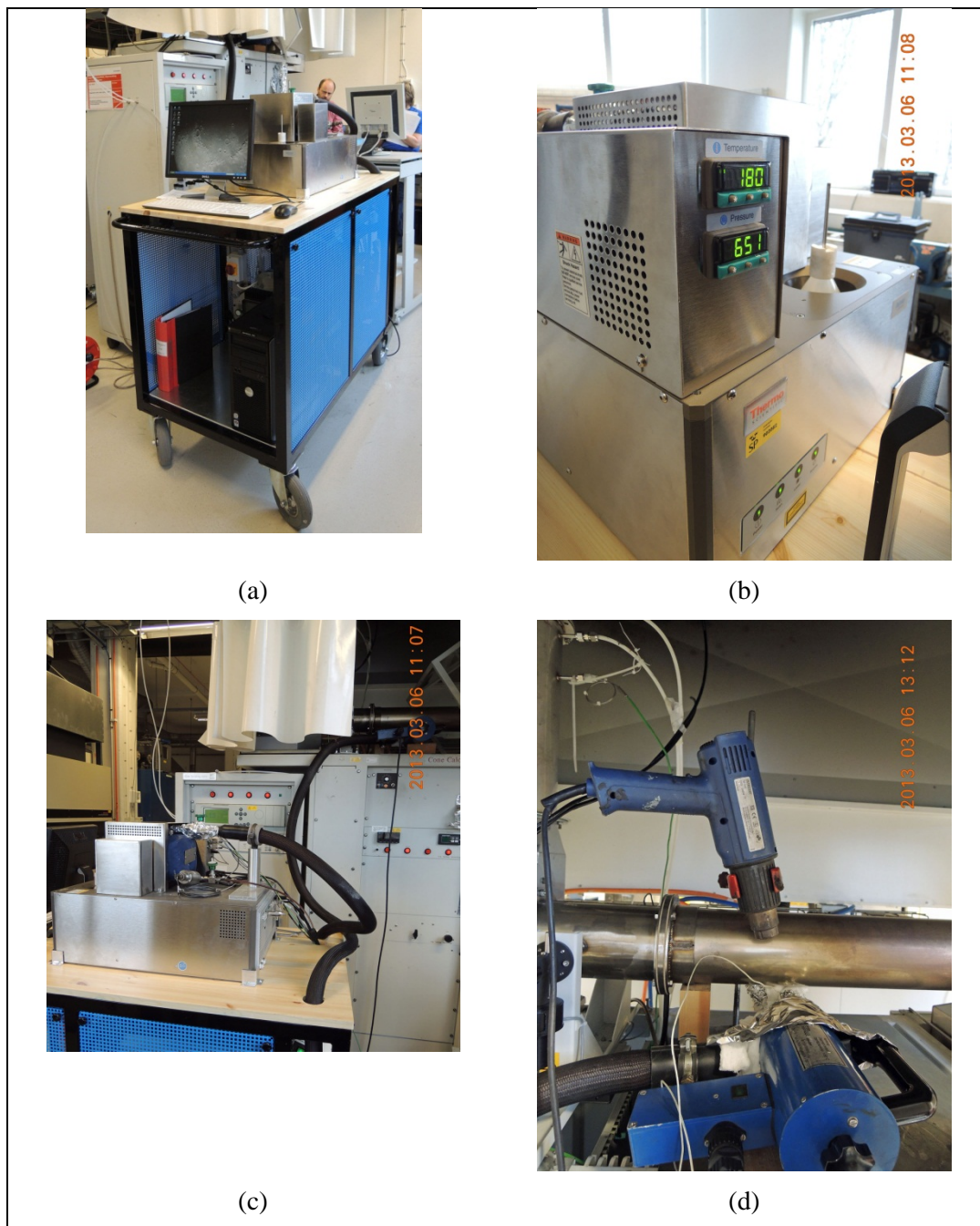
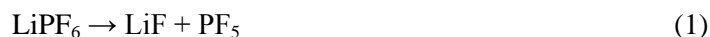

Figure 1 Photos of the FTIR instrumentation. (a) Overview of the measurement set-up. (b) The Antaris FTIR spectrometer. (c) The connection of the incoming sample gas to the measurement cell. (d) The primary filter with the heating device (blue in front) and heating of incoming connection with a heating gun.

3 Fundamental Chemistry of LiPF_6

When heated in a dry and inert environment LiPF_6 decomposes to lithiumfluoride (LiF) and phosphorouspentafluoride ($\text{PF}_5(\text{g})$)².



In contact with moisture/water PF_5 reacts to form phosphorous oxyfluoride and hydrogenfluoride.²



When heated in moisture/water LiPF_6 can directly form LiF, POF_3 and HF.²

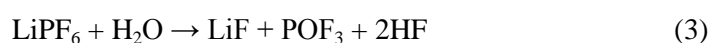

PF_5 also react with HF to form hexafluorophosphoric acid (HPF_6)³:



Phosphorous oxyfluoride (POF_3) can react to form several fluorinated phosphoric acids, monofluorophosphoric acid ($\text{H}_2\text{PO}_3\text{F}$), difluor-phosphoric acid (HPO_2F_2), hexafluorophosphoric acid (HPF_6), and phosphoric acid (H_3PO_4)⁴. The fluorinated phosphoric acids can react with water and yield HF and form phosphoric acid as a final product. [4]:

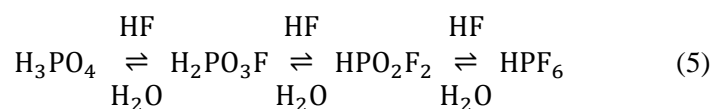

4 Pre-study of fluorinated emission products

In order to be able to study the fluorinated emission products emitted during a potential battery fire the FTIR to be used in the experiments had to be calibrated. The measuring method was then also verified by conducting experiments on electrolyte and salt solutions that were heated. The full calibration methodology is described below.

4.1 Production of calibration gases

The FTIR instrument contained a basic factory calibration for HF. This calibration was, however, improved during the project to include more spectral information and a wider concentration range. The calibration of HF was made using a dynamic dilution system where a water solution of HF was injected into a heated stream of nitrogen.

In addition was the FTIR calibrated for PF₅ and POF₃. Calibration gas mixtures were prepared for this purpose by dilution of PF₅ (99%, ABCR) and POF₃ (99%, ABCR) in nitrogen atmosphere using gasbags (Flexfoil, SKC). Extra effort was put into pre-conditioning the bags so they were free of water adsorbed to the walls. This was necessary to be able to prepare the highly reactive PF₅ mixture. The concentrations produced for the POF₃ calibration were: 25 ppm, 100 ppm, 200 ppm, 300 ppm and 416 ppm. While the PF₅ concentrations were 108 and 200 ppm, respectively.

4.2 Calibration of FTIR

The FTIR used had a calibration for a number of components when delivered from factory. These components included *e.g.* CO₂, CO and HF. It was seen that the factory calibration was not sufficiently accurate for the intended use of the instrument and the instrument was recalibrated during the course of this project. The settings of the FTIR instrument were changed somewhat (see Table 1) for the recalibration, which meant that measurements made before the recalibration could only be evaluated semi-quantitatively using recalibration data. This was not a problem, however, as the new calibration data was used in the evaluation of the project data.

4.2.1 HF

The instrument was recalibrated for HF during the project to include the full spectral band of HF and to include a wide concentration range *i.e.* 18 ppm to 1245 ppm. The quantification limit (LOQ) for HF was calculated to 2 ppm.

The spectral band at 520 ppm for HF (together with water) in nitrogen is seen in Figure 2. There are two branches of peaks for HF. The branch at the higher wavenumbers is clearly seen in the figure whereas the branch at lower wavenumbers contains interference from water bands.

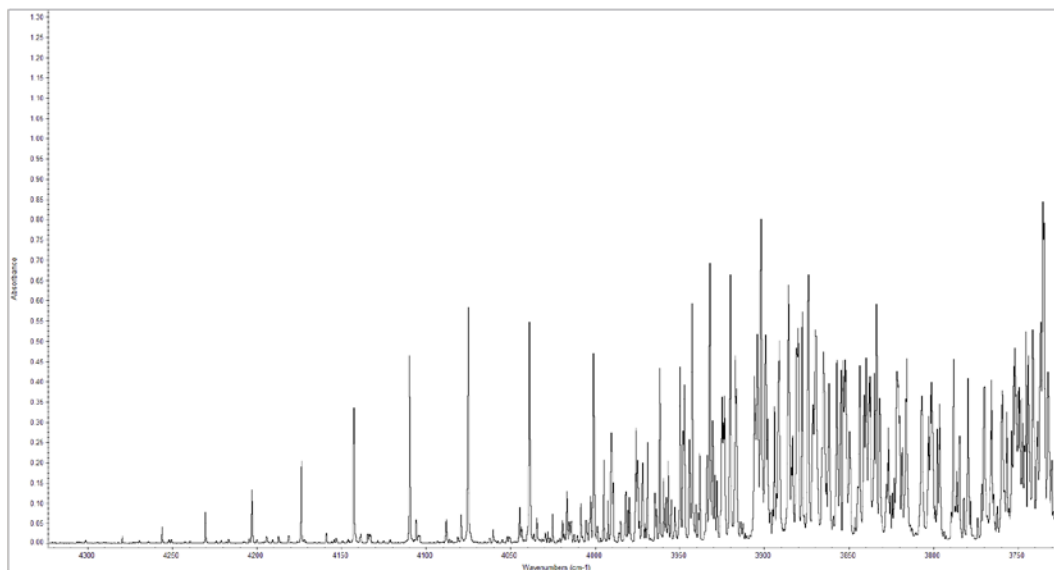

Figure 2 Spectra of 520 ppm HF and 2.9 % H₂O in N₂.

4.2.2 POF₃

Tests were conducted to record the spectral bands of POF₃ as a basis for calibration of the FTIR. An important part of the calibration work was further to investigate the stability of POF₃ under the conditions used for calibration (see section 4.3). This initial work was conducted before the FTIR was recalibrated.

A spectrum of POF₃ (116 ppm) is shown in Figure 3. Several distinctive absorption bands can be seen (together with some water that was present in the bag). These bands can be seen more clearly in Figure 4, where the spectral range of interest is shown.

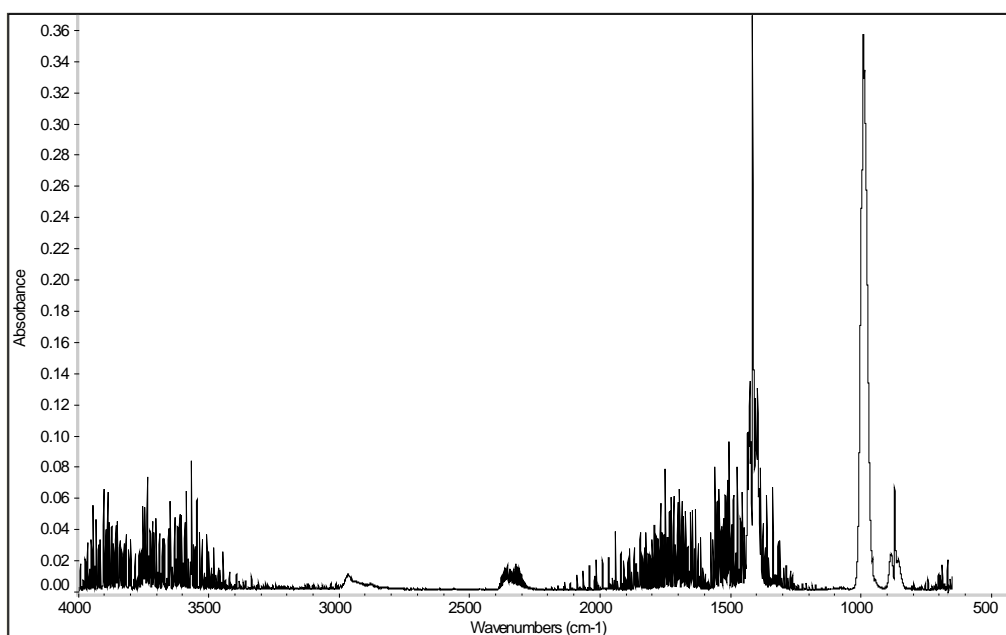

Figure 3 Spectra of 116 ppm POF₃ in N₂.

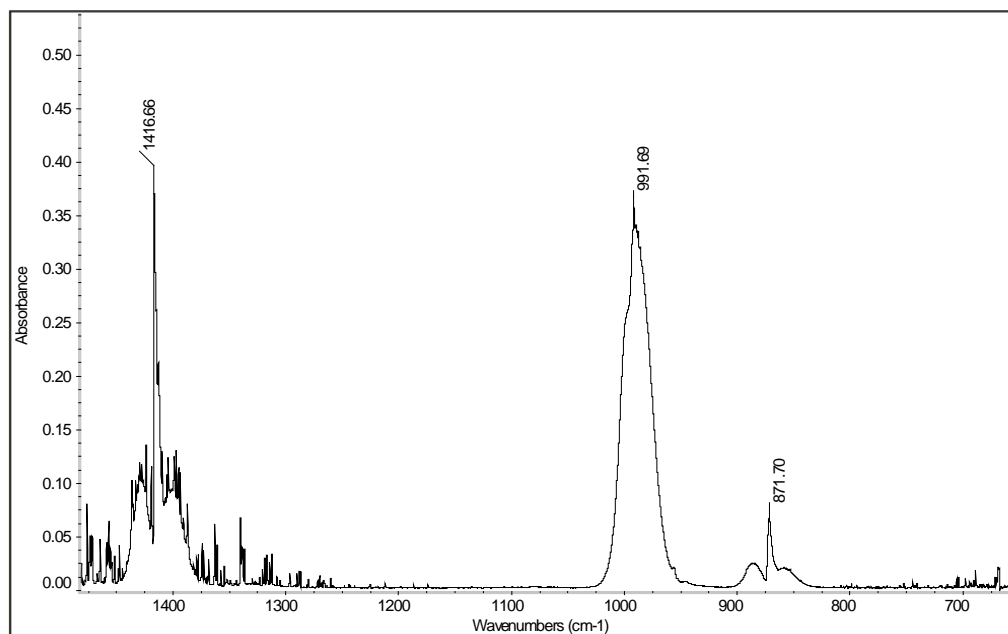

Figure 4 Spectral bands of POF_3 (from 116 ppm POF_3 in N_2).

Three spectral bands are shown centred around the wavenumbers 871 cm^{-1} , 991 cm^{-1} and 1416 cm^{-1} . These bands are from P-F symmetrical stretches, P-F asymmetrical stretches and P-O stretches. The two latter vibrations are the strongest. The spectral information of POF_3 is summarized in Table 2.

Table 2 Spectral band positions for POF_3 .

Band position (cm^{-1})	Absorptivity (abs/ppm.m)	Type of band [2]
1416	0.00159	P-O stretch
991	0.00154	P-F asymmetrical stretch
871	0.00029	P-F symmetrical stretch

A quantitative calibration was made for POF_3 using flushed gas bags where known volumes of POF_3 gas were injected into a known volume of nitrogen gas. The concentrations produced for the calibration were: 25 ppm, 100 ppm, 200 ppm, 300 ppm and 416 ppm. Spectral regions around 871 cm^{-1} and 1416 cm^{-1} were used for a CLS (classical least squares) calibration and water was included as an interfering component. The quantification limit (LOQ) for POF_3 was calculated to 6 ppm.

4.2.3 PF_5

It was found that the gas bags used needed to be dried by flushing with N_2 in order to remove any remaining water. Water was unwanted as hydrolysis of PF_5 could be expected. Figure 5 shows the FTIR spectrum of a non-flushed gas bag where the nominal concentration of PF_5 was 108 ppm. This spectrum shows, however, no significant spectral bands apart from those of POF_3 and HF. (Spectral bands of water, some CO_2 and a small contamination of HCl are additionally shown.)

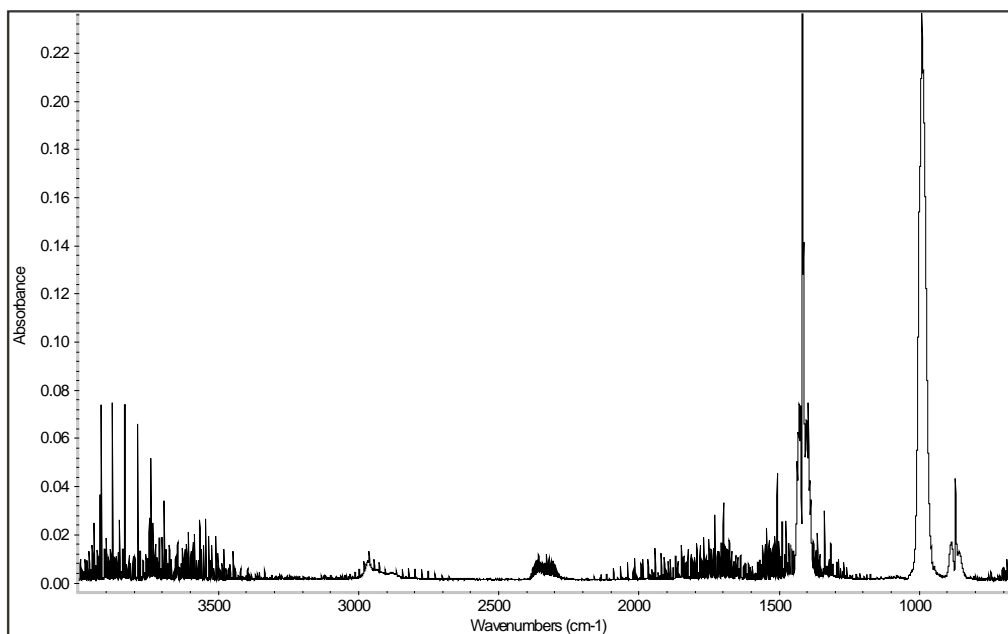

Figure 5 Spectra of 108 ppm PF₅ in argon (bag not flushed – contained water).

The explanation found was that the PF₅ added to the bag was hydrolysed by the small amounts of water that was present in the bag, to form the decomposition products POF₃ and HF.

The bags were subsequently thoroughly dried before adding PF₅. A spectrum from the content of a gas bag flushed with N₂ is shown in Figure 6. Only very small remains of water can be seen here.

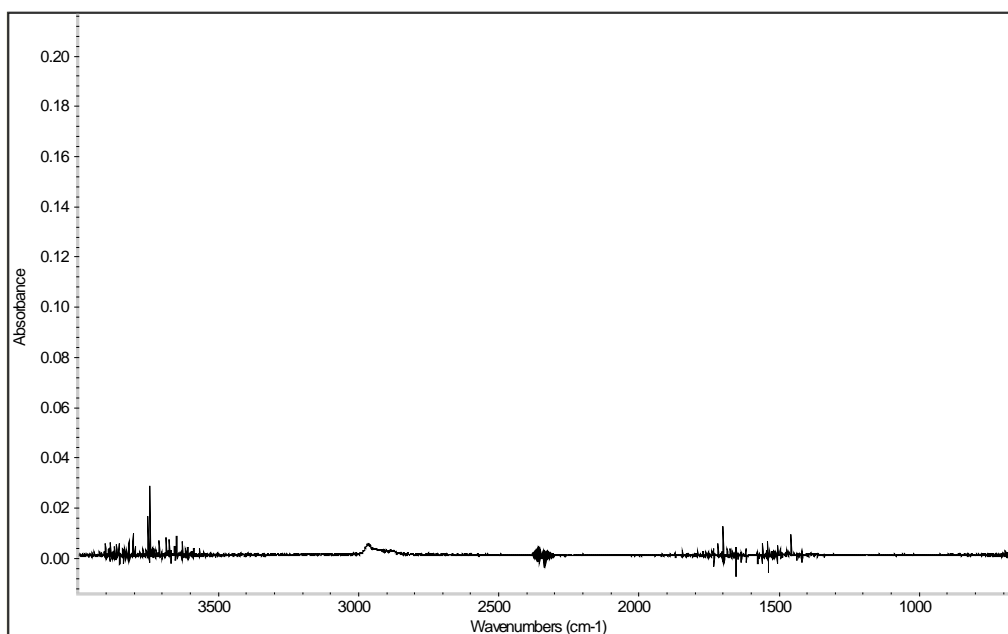

Figure 6 Spectra of gas content in gas bag flushed with dry N₂.

By using flushed bags it was possible to locate the spectral bands of PF₅. Figure 7 shows a spectrum of nominally 200 ppm PF₅ in N₂. However, also here the bands of POF₃ and HF can be seen together with the bands of PF₅. It is clear from this that PF₅ is very unstable and decomposes easily. The interesting spectral range for PF₅ is magnified in Figure 8.

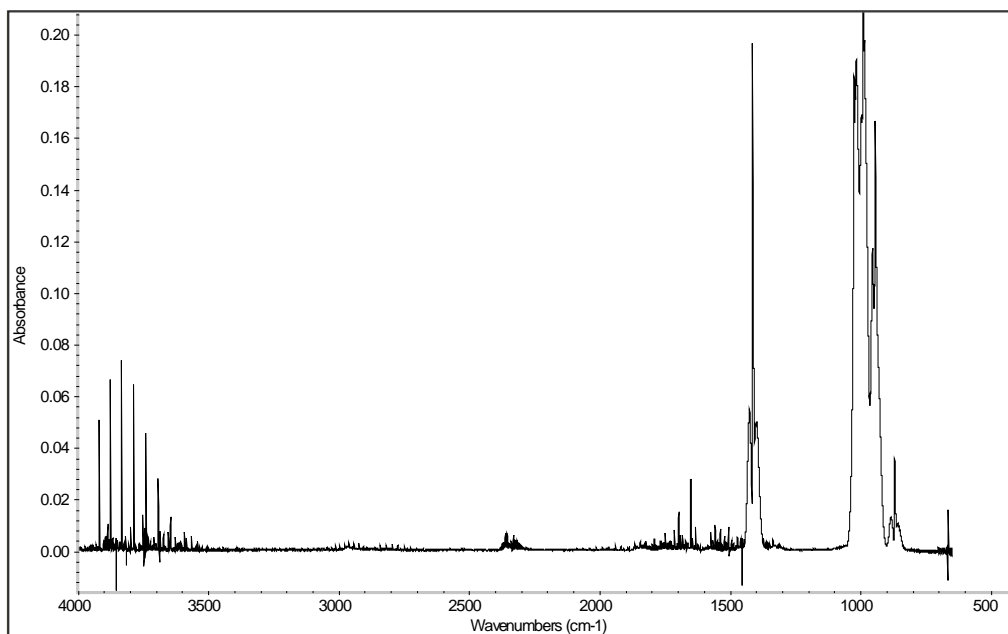

Figure 7 Spectra of 200 ppm PF_5 in dry N_2 (bag flushed).

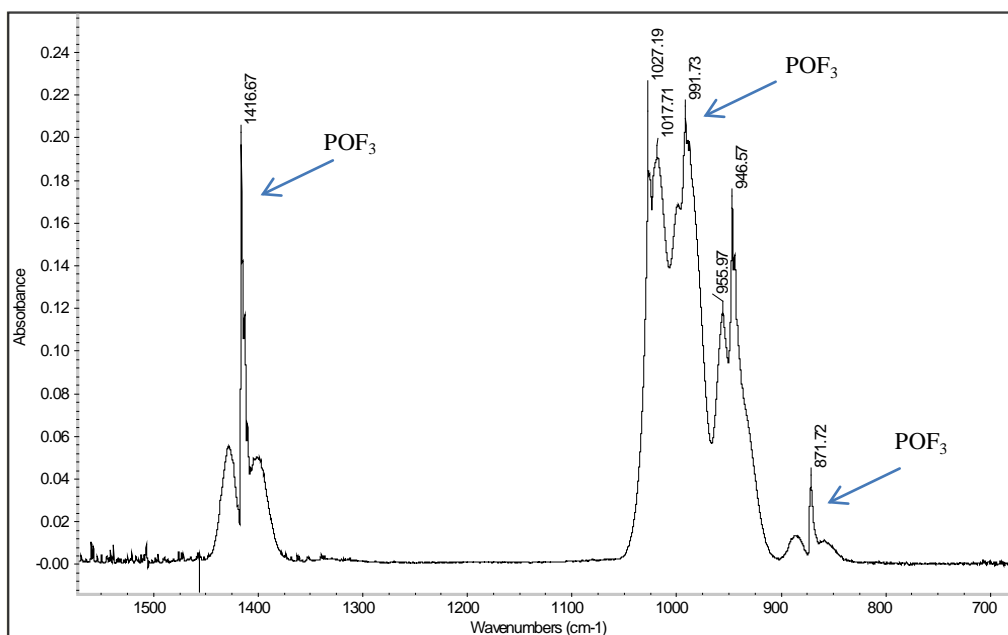

Figure 8 Spectral bands of PF_5 (from 200 ppm PF_5 in dry N_2).

The spectral bands of POF_3 are seen in Figure 8 at 871 cm^{-1} (P-F symmetrical stretch), 991 cm^{-1} (P-F asymmetrical stretch) and 1416 cm^{-1} (P-O stretch). Remaining bands are from PF_5 or additional decomposition products of PF_5 . PF_5 has two stretching modes according to Yang et al. [2]. These are most probably the bands at 1017.71 cm^{-1} and 946.57 cm^{-1} . The remaining two bands found, 1027 cm^{-1} and 996 cm^{-1} , must thus originate from unidentified decomposition products of PF_5 . The bands found that were not from POF_3 are listed in Table 3.

Table 3 Spectral band positions found from PF₅ and decomposition products.

Band position (cm ⁻¹)	Type of band
1017	PF ₅ : PF stretching [2]
946	PF ₅ : PF stretching [2]
1027	Band from unknown decomposition product
956	Band from unknown decomposition product
1416	POF ₃ : P-O stretch
991	POF ₃ : P-F asymmetric stretch
871	POF ₃ : P-F symmetric stretch

4.3 Stability of POF₃

The stability of POF₃ at both room temperature and at an elevated temperature was investigated. It was important to have this information to be sure that the calibration mixtures prepared in gas bags were stable and to see if any significant decomposition would take place in the heated sampling and measurement system.

4.3.1 Room temperature

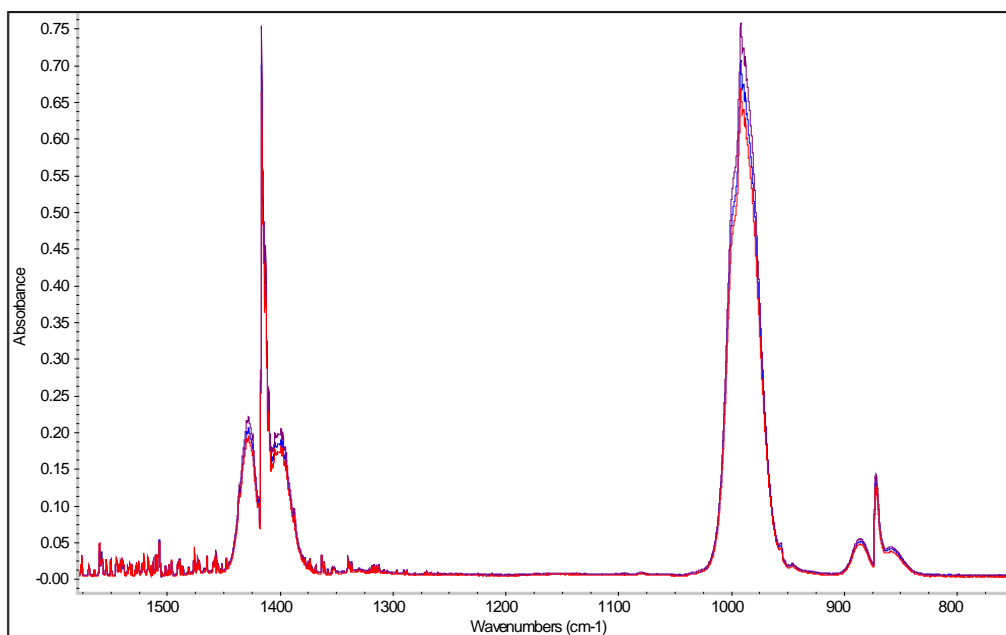

Figure 9 Spectra of ~200 ppm POF₃ measured in 3 separate Flexfoil bags at 8 min (blue), 16 min (brown) and 33 min (red) after preparation.

The investigation showed that POF₃ is very stable at room temperature in a gas bag diluted with N₂, which makes it possible to prepare quantitative calibration standards. Figure 9 shows the spectra of ~200 ppm POF₃ from three different gas bags, stored for various length of time before measurement. A very limited decomposition can be seen for the standard stored 33 minutes before measurement.

4.3.2 Elevated temperature

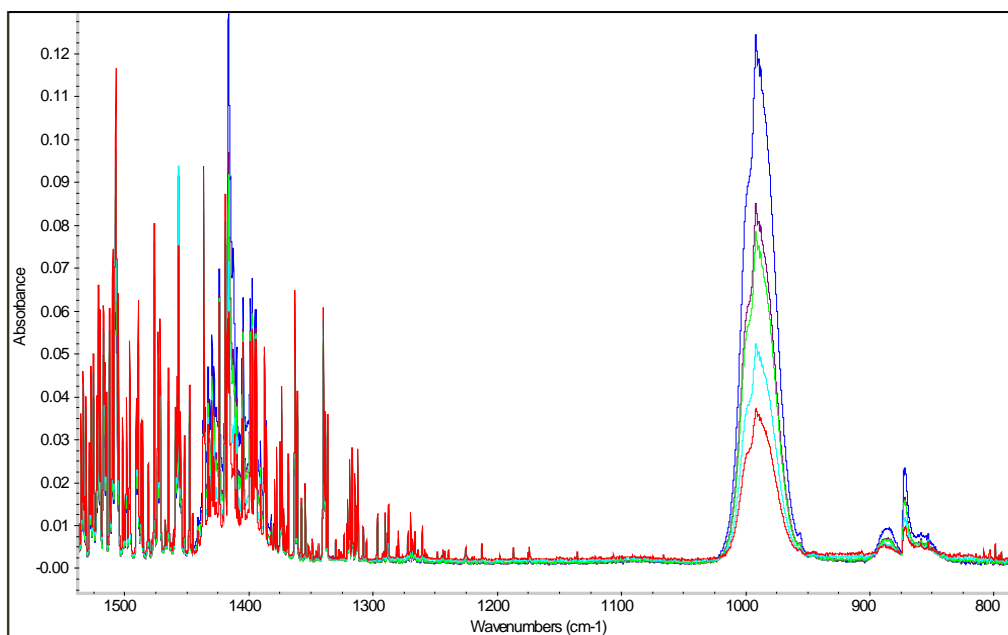

Figure 10 Series of spectra of 41 ppm POF_3 kept at 170°C in the FTIR gas cell for 0 min (blue), 8 min (brown), 10 min (green), 21 min (magenta) and 31 min (red).

The half-life for POF_3 in N_2 at 170°C is about 15 minutes according to the measurements shown in Figure 10, which means that there is no significant decomposition taking place in the measurement system during the ~ 10 s response time of the FTIR measurement set-up.

4.4 Heating tests with the Cone Calorimeter

Yang et al [2] have studied the thermal stability of LiPF_6 salt and of solutions of LiPF_6 in prototypical Li-ion battery solvents by thermogravimetric analysis (TGA) and on-line FTIR. They showed that in the presence of water the decomposition products formed were POF_3 and HF. No new products were observed in 1 molar solutions of LiPF_6 in EC, DMC and EMC. In the evaporation tests that are reported below it was investigated whether the same type of decomposition products could be found in tests where the electrolyte was heated in an open container with radiative heating in a Cone calorimeter. Further, combustion tests were conducted where the vapour was ignited to investigate how combustion would change the type of decomposition products.

The sample was placed in a small (~ 40 mm diameter) steel container under the heating cone of the Cone calorimeter as can be seen in Figure 11. The irradiation of the sample was in the range of $10\text{-}15\text{ kW/m}^2$. The FTIR was connected to the exhaust duct of the Cone calorimeter. Separate tests were conducted with only solvents (DME and PC), the pure LiPF_6 salt, and saturated solutions of LiPF_6 salt and solvents. Leftovers from the tests can be seen in Figure 12. The FTIR measurement system is described in Section 2.



Figure 11. Open container placed underneath cone heater and ignited



Figure 12. Leftovers in cake-cup after test

4.4.1 Evaporation tests of pure components

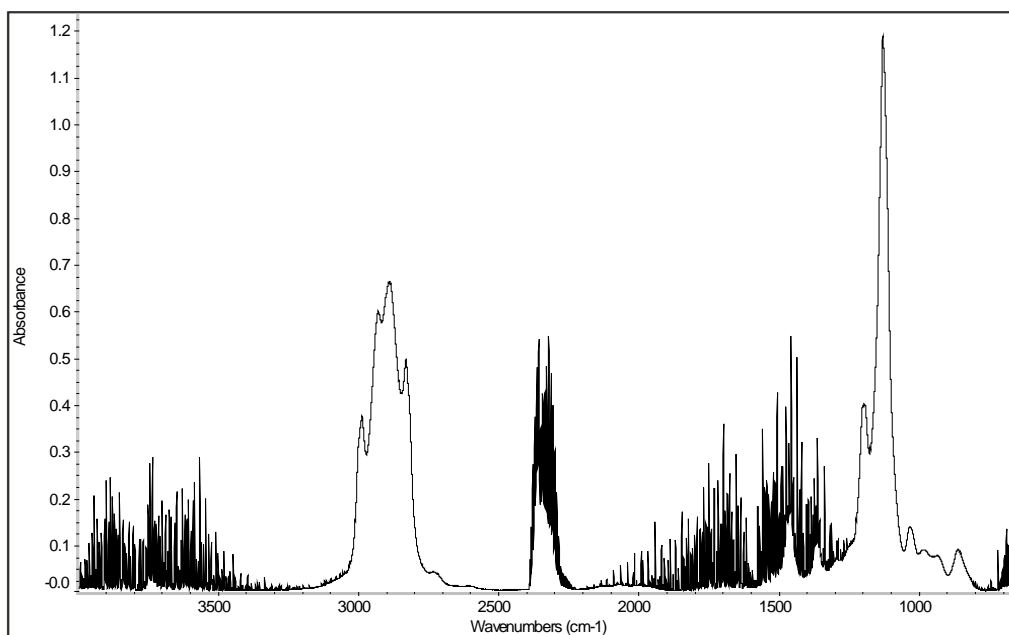

Figure 13 Spectra of Dimethoxyethane (DME) evaporated in the Cone Calorimeter.

Figure 13 shows a spectrum of DME when evaporating from heating in the cone calorimeter with absorption bands around 1100 cm^{-1} and 2900 cm^{-1} . The highest distinctive peak is located at 1129 cm^{-1} .

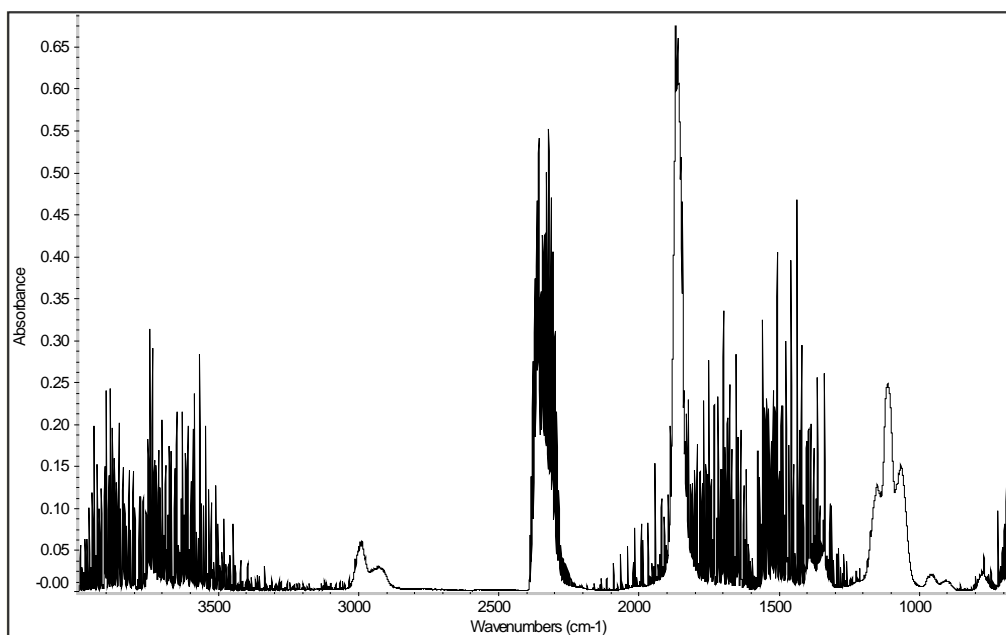

Figure 14 Spectra of Propylene carbonate (PC) evaporated in the Cone Calorimeter.

Figure 14 shows a spectrum of PC when evaporating from heating in the cone calorimeter with absorption bands around 1100 cm^{-1} , 1850 cm^{-1} and 2950 cm^{-1} . The two highest distinctive peaks are located at 1114 cm^{-1} and 1867 cm^{-1} .

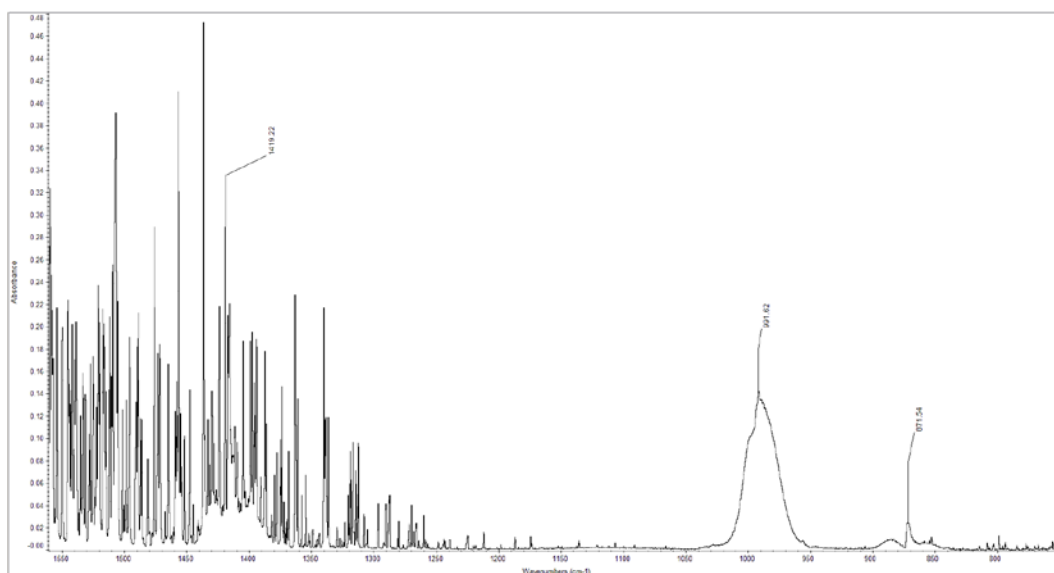

Figure 15 Spectral bands of evaporation products from Lithium hexafluoride.

Figure 15 show the spectral bands of POF_3 in a test where pure LiPF_6 salt was thermally decomposed in the cone calorimeter. HF could only be qualitatively identified here (not shown) as severe interference of water made quantification impossible in the region up to 4000 cm^{-1} which was the highest wavenumber measured in these early tests.

There are no traces of PF_5 or any decomposition products apart from POF_3 in the spectral range shown in Figure 13.

4.4.2 Evaporation tests with mixtures of components

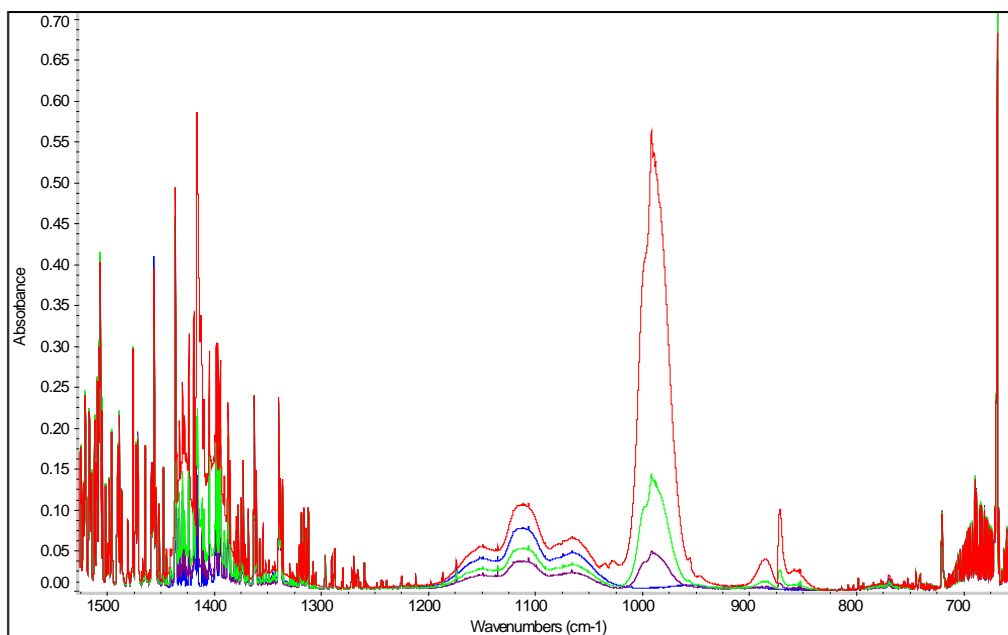

Figure 16 Series of spectra from evaporation test with LiPF_6 mixed in Polypropylene carbonate (PC). Spectra measured at 57 s (brown), 82 s (green), 157 s (red) and 257 s (blue) after start of heat exposure.

Spectra from an evaporation test with a saturated solution of LiPF_6 salt in PP are shown in Figure 14 above. The spectral band from the solvent is shown around 1100 cm^{-1} together with the three bands of POF_3 at 871 cm^{-1} , 991 cm^{-1} and 1416 cm^{-1} . It can be seen from the overlaid spectra that the emission of POF_3 ends before the solvent is totally evaporated (see blue spectrum from 257 s in Figure 14).

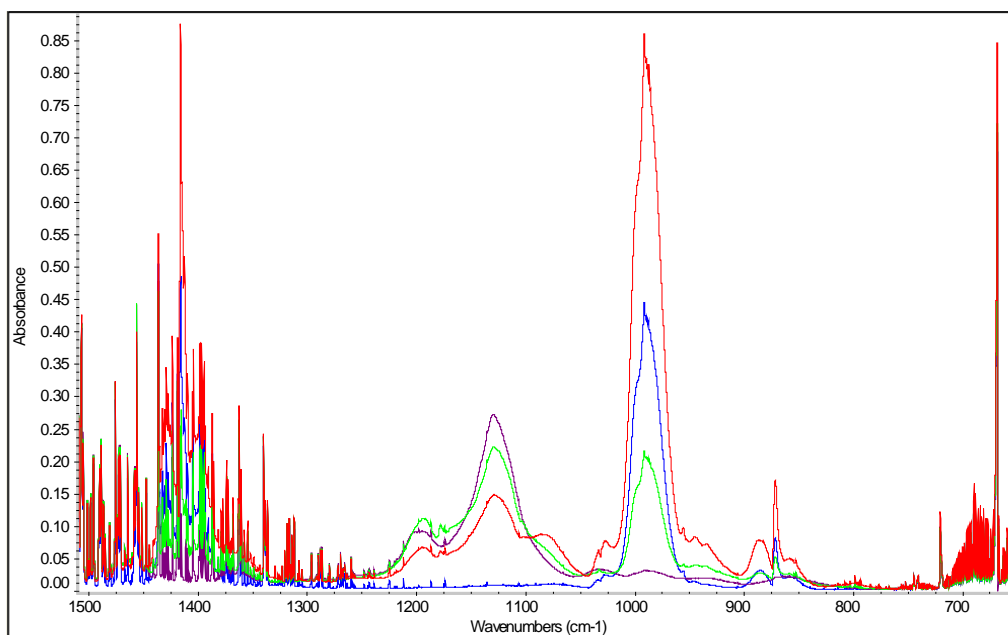

Figure 17 Series of spectra from evaporation test with LiPF_6 mixed in Dimethoxyethane (DME). Spectra measured at 30 s (brown), 67 s (green), 117 s (red) and 155 s (blue) after start of heat exposure.

Figure 17 shows a series of spectra from an evaporation test with a saturated solution of LiPF_6 salt in DME. Also here the spectral band from the solvent is shown around 1100 cm^{-1} together with the three bands of POF_3 at 871 cm^{-1} , 991 cm^{-1} and 1416 cm^{-1} . Here it can be seen from the overlaid spectra that the emission of POF_3 continues after that the solvent is totally evaporated (see blue spectrum from 155 s in Figure 15). This is the opposite behaviour compared to the solution of LiPF_6 salt in PC. One cannot, however, draw any conclusion from this as the emission behaviour of POF_3 here might be an effect of the saturation degree of the two mixtures.

4.4.3 Combustion tests

Test where saturated solutions of LiPF_6 salt in DME respective PC, were ignited in the cone calorimeter are reported below. In these tests the same level of external radiative heat flow was used as for the evaporation tests discussed above ($10\text{--}15\text{ kW/m}^2$). However, in these tests the electric spark igniter was used to ignite the evaporated fumes over the sample container.

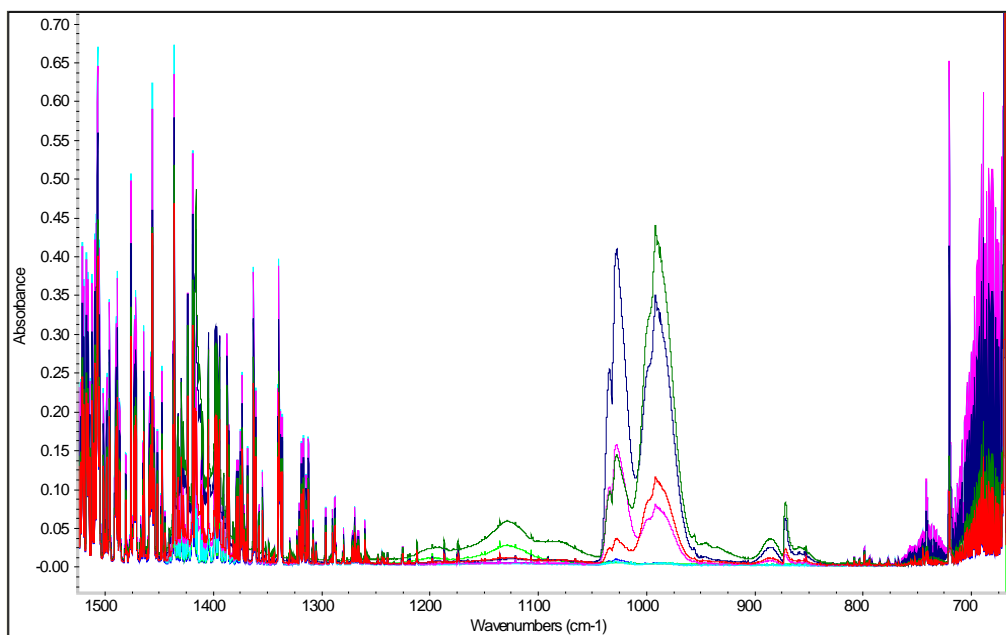

Figure 18 Series of spectra from fire test with LiPF_6 mixed in Dimethoxyethane [DME]. Spectra measured at 5 s (light green), 29 s (aqua), 42 s (pink), 54 s (black), 67 s (dark green), 79 s (red) and 104 s (blue) after start of heat exposure. Ignition at 2 s after start. Flame-out at 95 s.

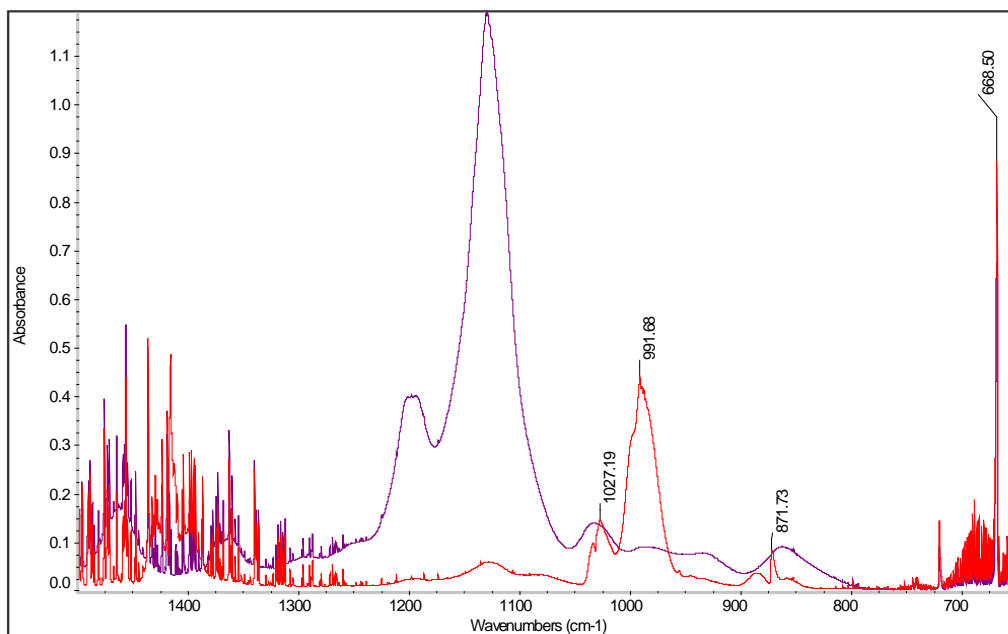

Figure 19 Spectra from the fire test with LiPF_6 mixed in DME at 67 s from start of test (red). Overlaid by spectra from evaporation test with DME (purple).

A series of spectra (overlaid) are shown in Figure 18 from the tests with LiPF_6 salt in DME. One can clearly see the characteristic spectral features of POF_3 during the period of combustion (2-95 s). Also HF was seen in the spectrum during this period (not shown above). The spectral band from the solvent is shown only in the first few spectra and in the spectrum from 67 s (see Figure 19). The combustion efficiency must have decreased at this time but extinction was not recorded until 95 s.

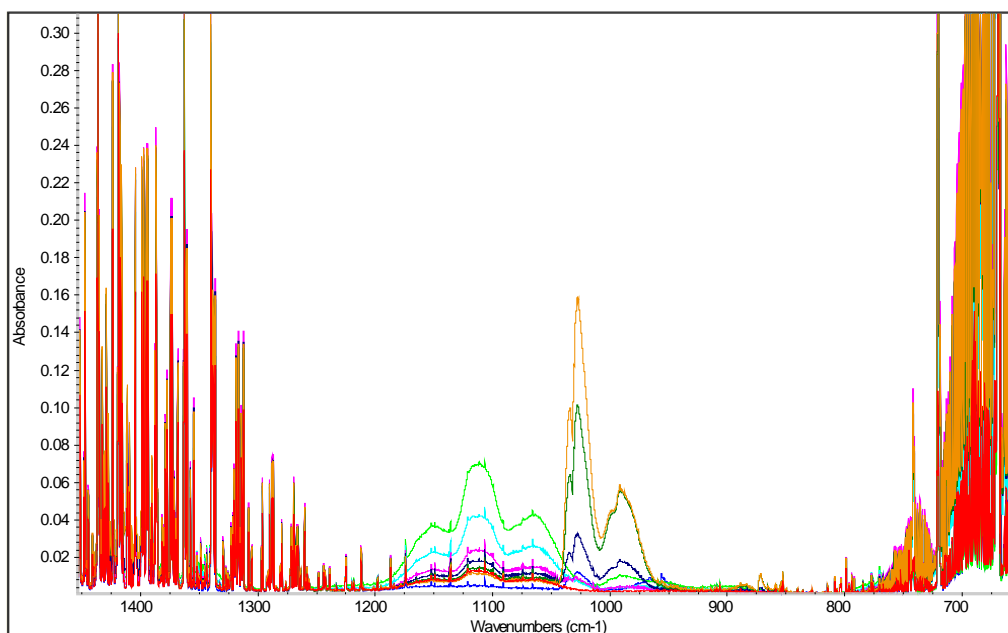

Figure 20 Series of spectra from fire test with LiPF_6 mixed in Polypropylene carbonate (PC). Spectra measured at 28 s (red), 53 s (light green), 78s (aqua), 90 s (pink), 103 s (black), 116 s (dark green), 128 s (orange) and 190 s (dark blue) after start of heat exposure. Ignition at 1 min 11 s after start. Flame-out at 170 s.

Figure 20 shows a series of spectra (overlaid) from the tests with LiPF_6 salt in PC. The spectral bands of POF_3 (the band at 992 cm^{-1} can be clearly seen in the figure) were seen in the spectra during the period of combustion (71-170 s). Also HF was seen as in the

spectra during this period (not shown above). The spectral band from the solvent is clearly shown in the spectra before combustion.

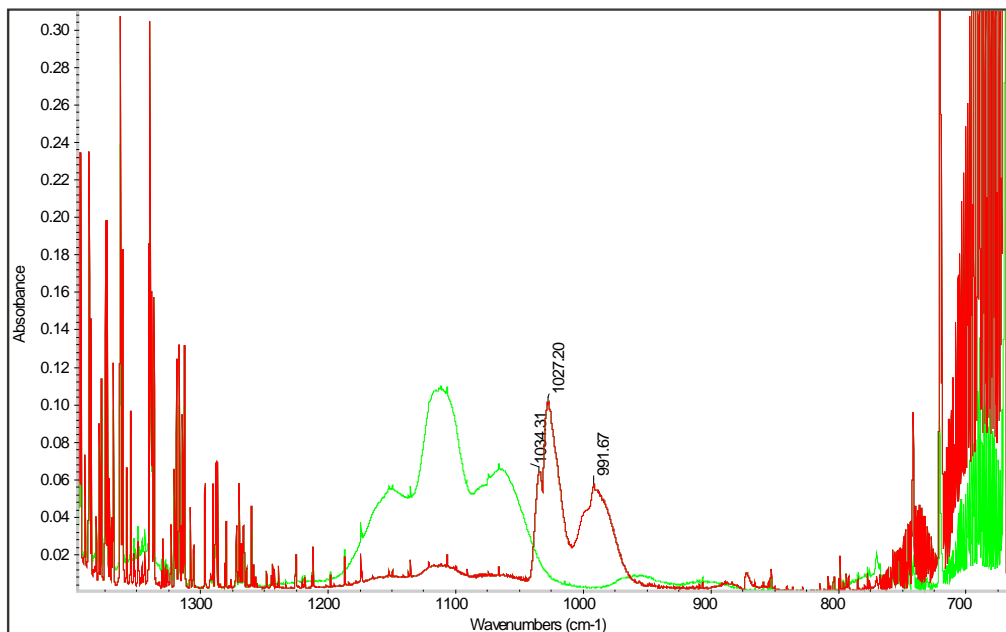

Figure 21 Spectra from the fire test with LiPF_6 mixed in Polypropylene carbonate at 116 s from start of test (red). Overlaid by spectra from evaporation test with Polypropylene carbonate (light green).

Figure 21 shows the spectrum collected at 116 s into the combustion test with LiPF_6 salt in PC. The spectra of pure PC has been overlaid. Also here one can see two additional peaks which do not originate from POF_3 , one at 1027 cm^{-1} and one at 1034 cm^{-1} .

The combustion tests with electrolyte solvents of LiPF_6 salt showed that HF and also POF_3 are present in the combustion effluents. This is an important finding. Further, unidentified spectral absorption bands indicate the presence of an additional, possibly fluorine containing, decomposition product.

5 Burner tests with electrolyte

Tests were conducted by using a small propane burner about 2 cm in diameter in which electrolyte salt solutions were introduced through needles or on a spoon as seen in Figure 21. The amount of propane inserted was controlled by a variable area flow-meter. Two different amounts of propane were used, i.e. 7 scale points on the flow meter scale and 5 scale points. The Heat Release Rate (HRR) was measured in all tests. The HRR was found to be 4.8 kW for the 7 scale point case (referred to as the “normal case” below) and 3.2 kW for the 5 scale point case (referred to as the “lower case” below). The amount of electrolyte inserted was controlled by two HPLC pumps.

The Heat Release Rate from the fire was measured by using Oxygen Consumption Calorimetry in the cone calorimeter hood. In some experiments the cone heater and load cell was used. FTIR measurement were made in all tests. The FTIR measurement system is described in Section 2. A schematic of the cone calorimeter is provided in Figure 20.

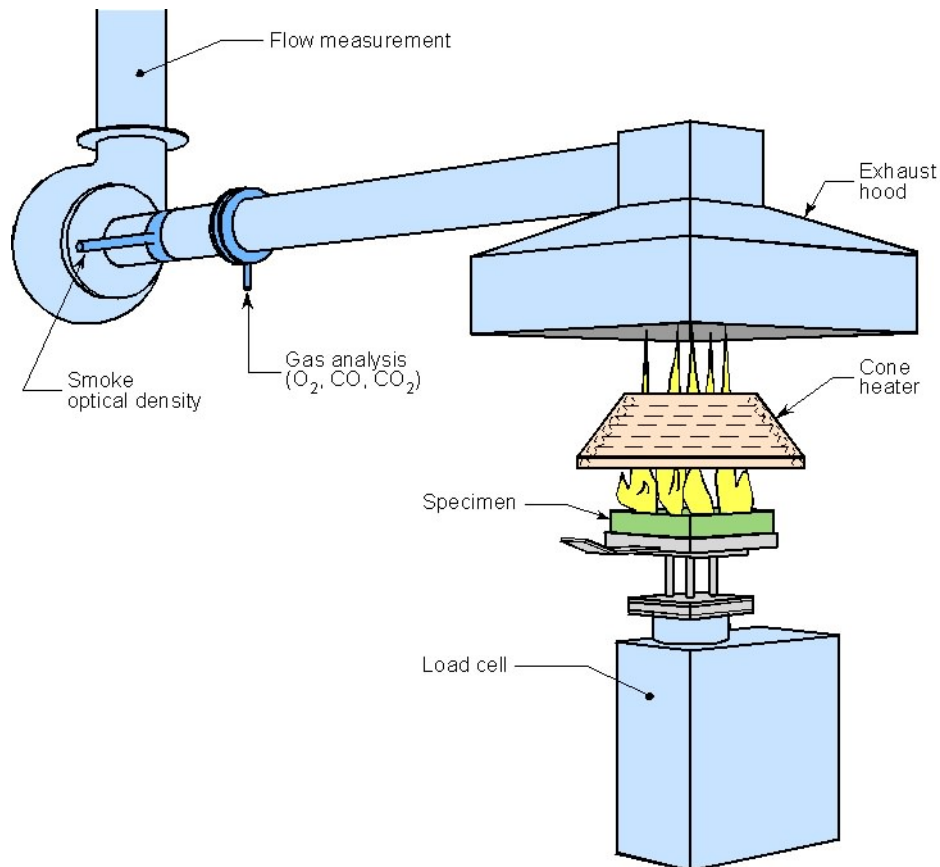

Figure 22 The cone calorimeter. The heater and load cell was not used in the major part of the tests.

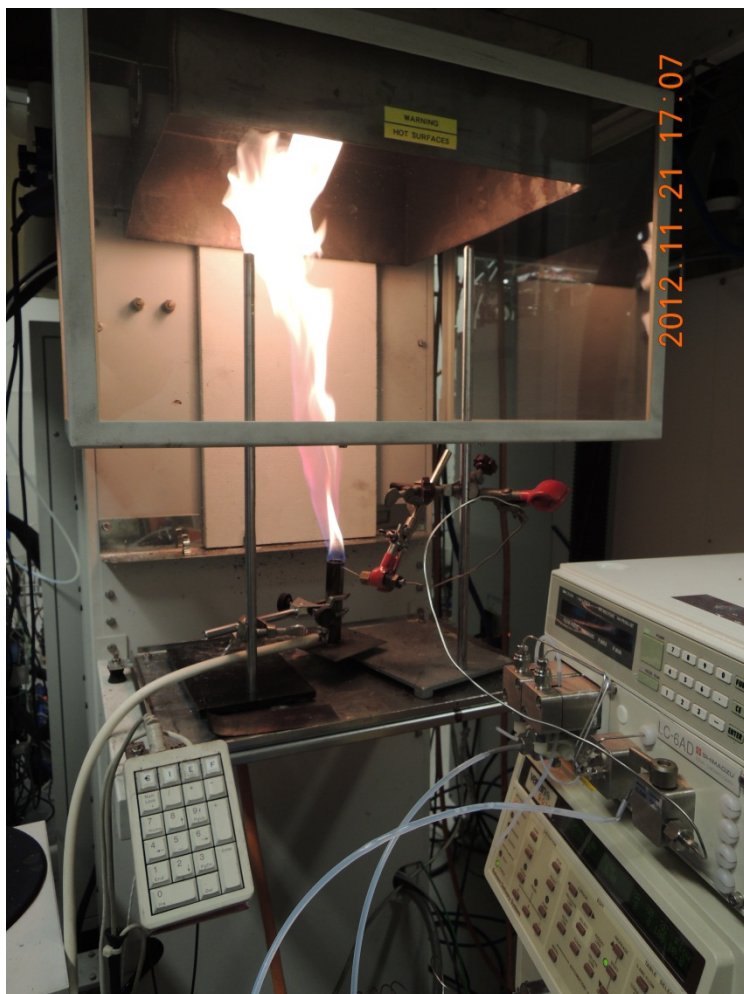

Figure 23 Experimental set-up with the needle inserted in the burner.

5.1 Electrolyte – salt solutions

Solutions of LiPF_6 (99 %, Sigma-Aldrich) were prepared by dilution in dimethylcarbonate (DMC, 99% Sigma-Aldrich) and 1,2-dimethoxy ethane (DME, 99% Sigma-Aldrich). The DMC solutions were 1.0 M and 0.4 M respectively and the DME solution was 0.4 M.

5.2 Tests conducted

Tests were conducted in two batches. In the first batch it turned out that the needles became clogged with the salt and it was difficult to produce a spray. Custom made needles were therefore ordered and a new batch of tests was conducted with the new needles.

Tests conducted in the first batch are listed in Table 4. Further description of the test procedures and results is provided in Appendix A. In this batch the propane flow was the same in all tests. The way the solvent and salt were introduced into the flame was varied and the amount was varied. Due to difficulties with achieving a stable spray and clogging of the needles it was not possible to conduct any tests where water was introduced together with salt and solvent.

Table 4 Tests conducted in first batch.

Test nr	Type of test	Fuel	Comment
1	burner	Propane only	Initial test to determine propane HRR
2	Burner + needle	Propane and 5.9 ml/min DME	DME works not as spray but as a beam, possibility that all DME not burnt
3	Burner + Needle	Propane and 5.9 ml/min DME	Needle in bottom of burner instead of top
4	Burner + Needle	Propane and 5.9 ml/min DME	Needle inserted outside of burner
5	Burner + spoon	Propane and 2.4 ml/min DMC	Not a very successful attempt
6	Burner + Needle	Propane and 12 ml/min DMC	and later 5 ml/min
7	Burner + Needle	Propane and 20 ml/min DMC	Interrupted as holder melted
8	Burner + Needle	Propane and 20-18 ml/min DMC	Burner placed a bit lower under the collecting hood
9	Burner + Needle	Propane and DMC 18 ml/min	
10	Burner + Needle	Propane and DMC 18 ml/min with 1 M salt	
11	Burner + needle	Propane and DME 18 ml/min	
12	Burner + needle	Propane and DME 18 ml/min with 0.4 M salt	
13	Burner + Needle	Propane and DMC 18 ml/min 1 M salt	
14	Burner + Spoon	Propane and DMC 1.8 ml/min	
15	Burner + spoon	Propane and DMC 1.8 ml/min + 1M salt	
16	Burner + spoon	Propane and DME 1.8 ml/min + 0.4 M salt	
17	cakecup	DMC + salt 1:1	No external heating, did not burn very well
18	cakecup	DME + salt 1:1	No external heating, did not burn very well

The tests conducted in the second batch are presented in Table 5, additional information about the test procedures can be found in appendix A. The tests were conducted using the same burner as used in the first batch of tests. Two different propane flows were used, 7 and 5 scale points on the flow meter, resulting in a HRR of 4.8 and 3.2 kW respectively. These HRR levels were in the same order of magnitude as the HRR resulting from the electrolyte burning. Most of the tests were conducted on DMC. The salt concentration in the DMC was varied together with the amount of DMC introduced into the flame. In

addition some tests were conducted where water was introduced into the flame. The duration of these tests was however, limited because despite careful design of needles that were custom made for this project we encountered problems with creating a stable spray for long periods of time.

Table 5 Tests conducted in second batch.

Test nr	Injection	Other conditions
20	none	Normal propane 7 sp
21	none	Normal propane and water 7 - 8 min and 10 - 11 min
22	15 ml/min 2 min 1 M = 30 ml M	Normal propane 7 sp DMC
23a	15 ml/min 4.5 min 0.4M = 27 ml M	Normal propane during 3 minutes, lower during 1.5 min DMC
23b	15 ml/min 3 min 0.4M = 18 ml M uncertainty for the 15 ml/min, according to HRR only about half	5 skd propane DMC
24	10 ml/min 3 min 1 M (initial 5 minutes injection problematic)	7 sp propane, short while at end with water injection DMC
25	15 ml/min 1 M 2:45 = 41 ml M	7 sp propane DMC
26a	15 ml/min 1 M 1:45	7 sp propane DMC
26b	Cleaning system with water	
26c	15 ml/min 1 M 1:30	7 skd propane, water at end DMC
27	1 M salt in DMC in cakecup	
28	0.4 M salt in DME in cakecup	

5.3 Test Results

Results from tests where LiPF_6 salt was injected in the first test batch are presented in Figure 22 - Figure 36. For these tests is HRR presented together with an indication of when different injections were conducted by means of coloured lines in the graphs. In addition are graphs presented with HRR on the left axis and the HF concentration in the exhaust duct on the right hand side axis. Finally one graph is presented for each of these tests where the HF concentration in the exhaust duct is given on the left hand side axis and the POF_3 concentration in the duct on the right hand side axis.

When studying the graphs it is important to remember that the concentrations presented are concentrations in the exhaust duct. These depend on the gas flow in the exhaust duct and the amount of salt and electrolyte introduced into the flame. They should not be considered as the concentration in the vicinity of a burning vehicle but are only presented here as concentrations in order to evaluate changes in amount produced due to changes in flame composition etc.

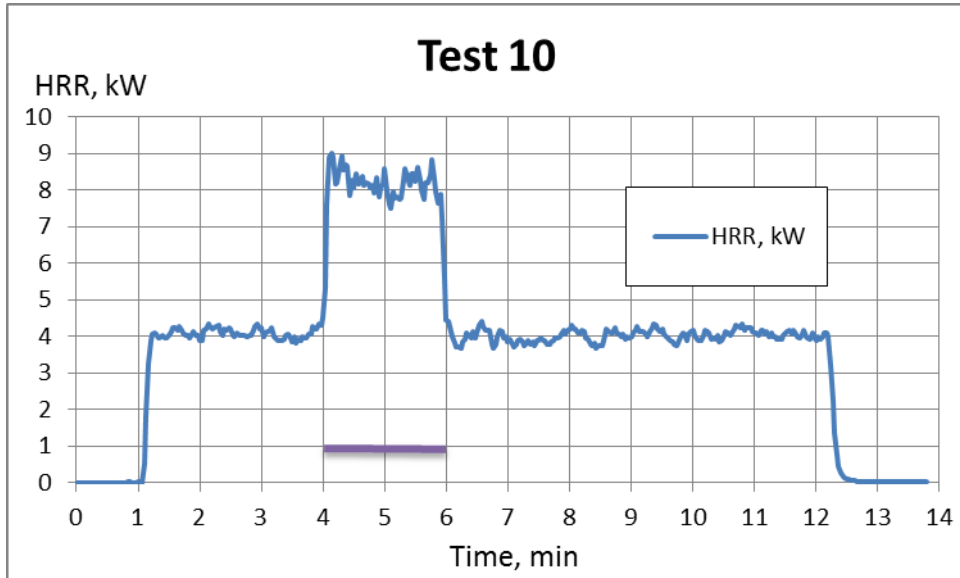

Figure 24 Heat Release Rate (HRR) from test 10. DMC and salt injection (18 ml/min with 1 M salt) indicated as a purple line between time 4 and 6 minutes.

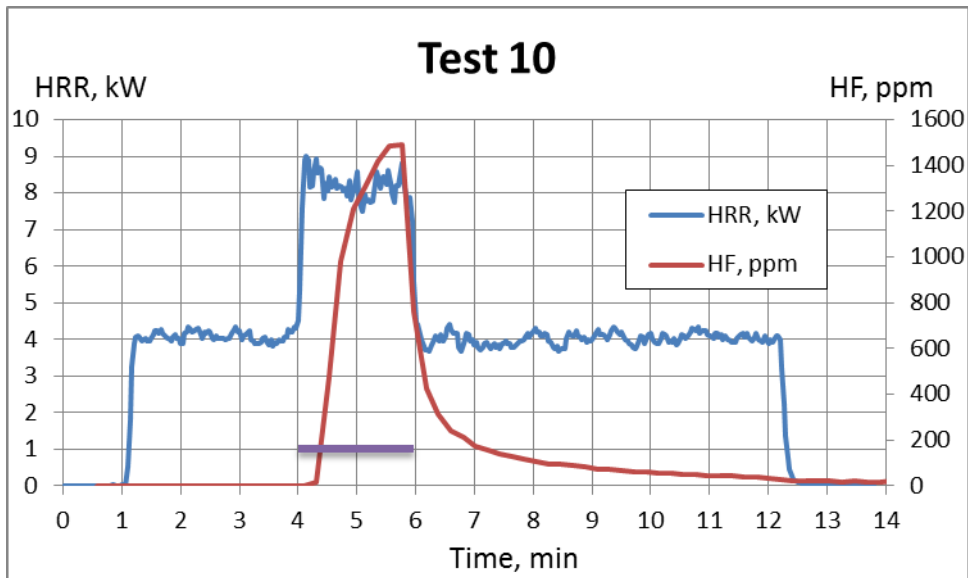

Figure 25 HRR and HF concentration during Test 10. DMC and salt injection (18 ml/min with 1 M salt) indicated as a purple line between time 4 and 6 minutes.

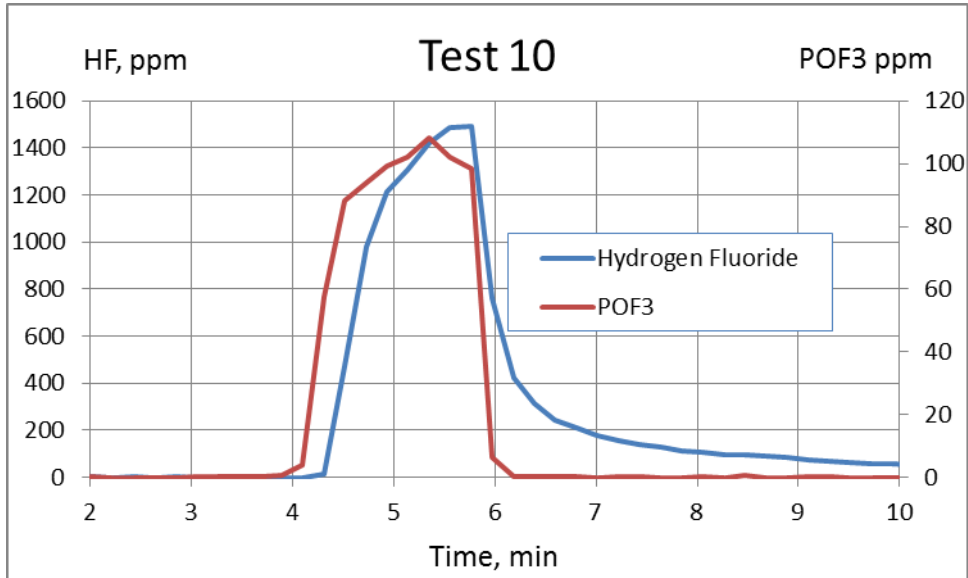

Figure 26 HF and POF₃ concentration as a function of time for test 10. DMC with salt was injected during time 4 to 6 minutes.

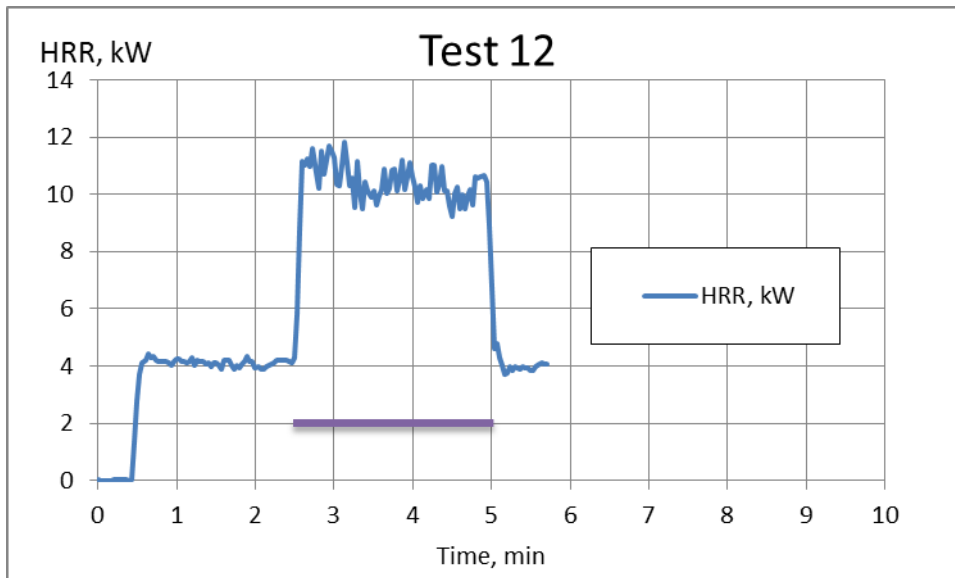

Figure 27 HRR as function of time for test 12. The time period under which DMC with salt was introduced into the flame is indicated with a purple line (2.5 minutes – 5 minutes).

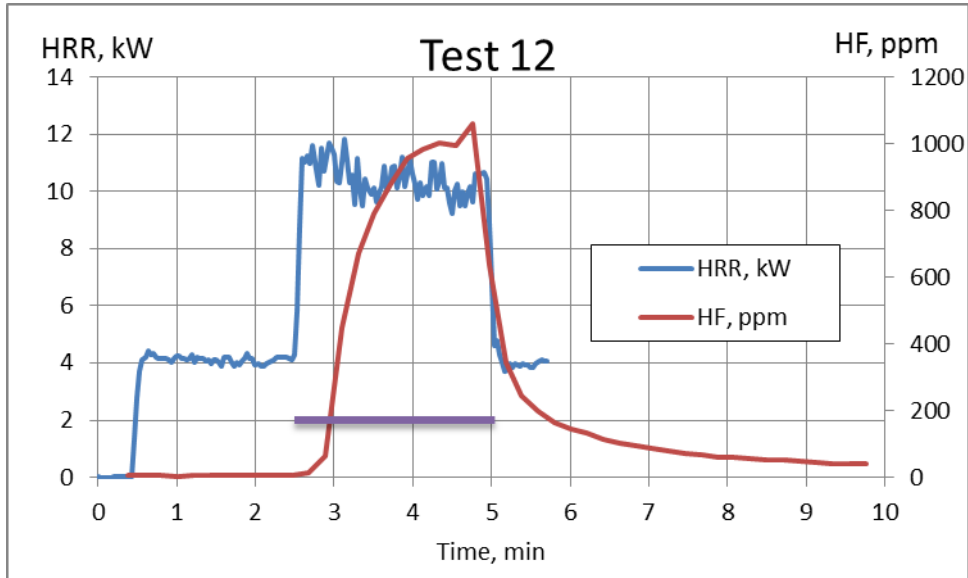

Figure 28 HRR and HF concentration as function of time for test 12. The time period under which DMC with salt was introduced into the flame is indicated with a purple line (2.5 minutes – 5 minutes).

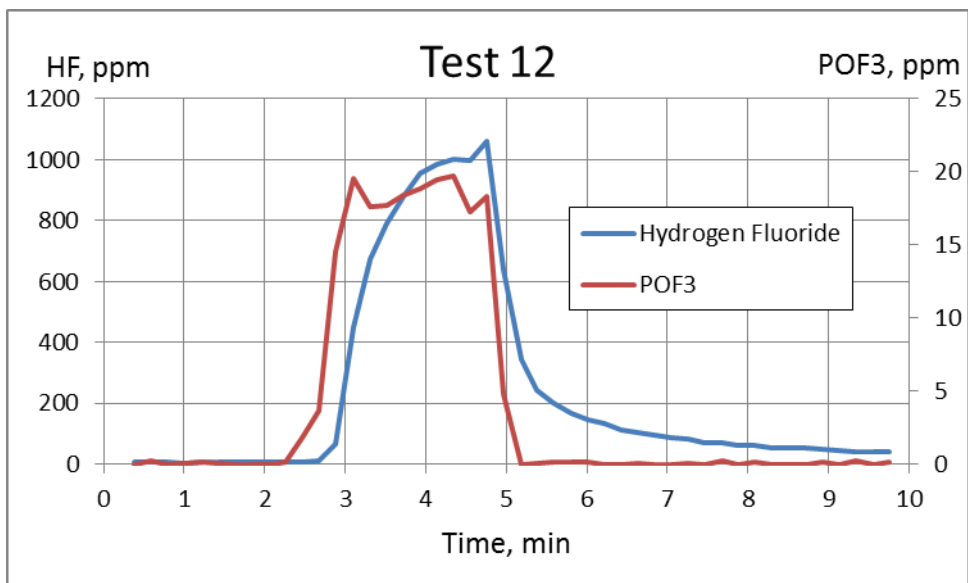

Figure 29 HF and POF₃ concentration as a function of time for test 12. DME with salt was injected during time 2.5 to 5 minutes.

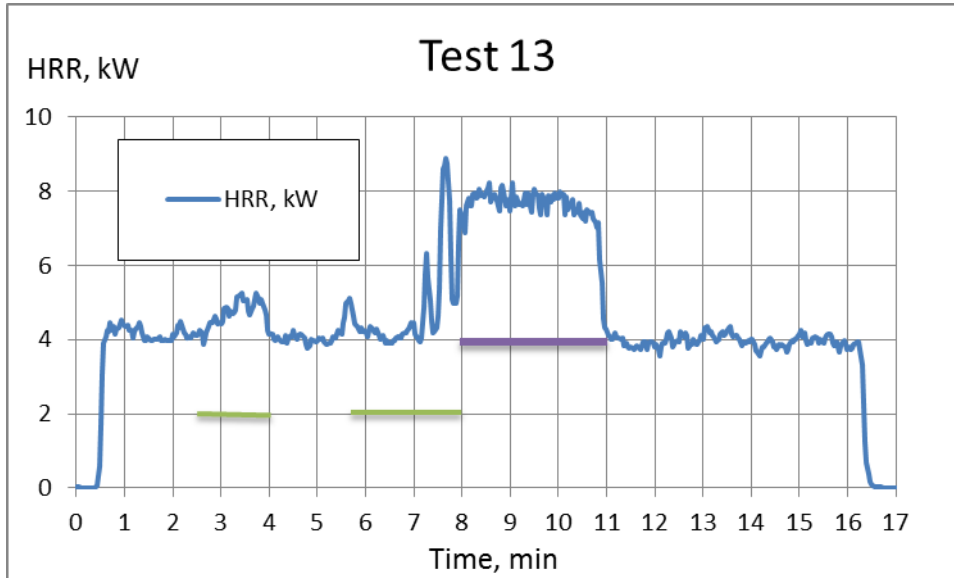

Figure 30 HRR as function of time for test 13. Initial spray attempt with DMC starting at 2:30 had to be interrupted at 4:00 due to difficulties with spray. Second period of pure DMC at time 5:40 until 8:00, both DMC periods indicated with green line in figure. The time period under which DMC with salt was introduced into the flame is indicated with a purple line (8 minutes – 11 minutes).

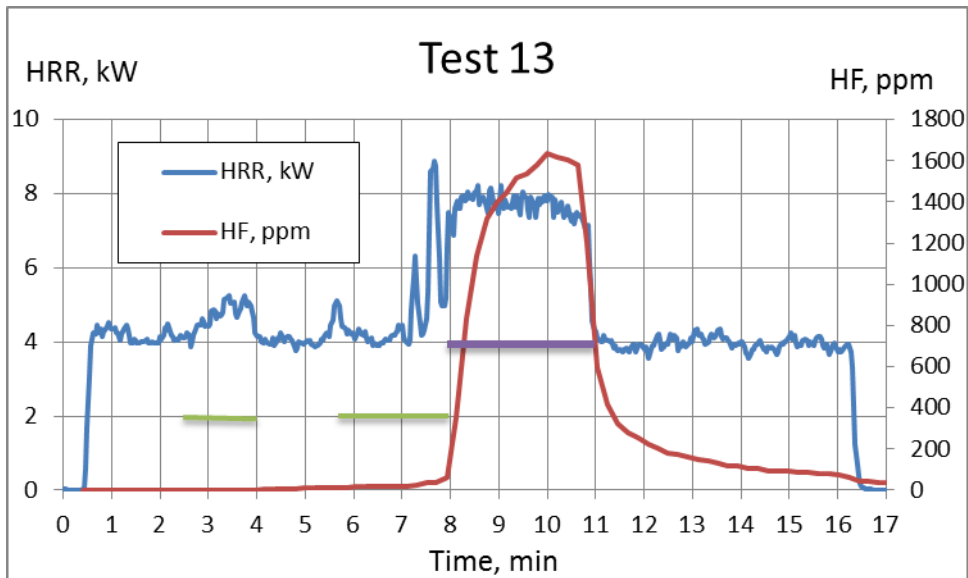

Figure 31 HRR and HF concentration as function of time for test 13. Initial spray attempt with DMC starting at 2:30 had to be interrupted at 4:00 due to difficulties with spray. Second period of pure DMC at time 5:40 until 8:00, both DMC periods indicated with green line in figure. The time period under which DMC with salt was introduced into the flame is indicated with a purple line (8 minutes – 11 minutes).

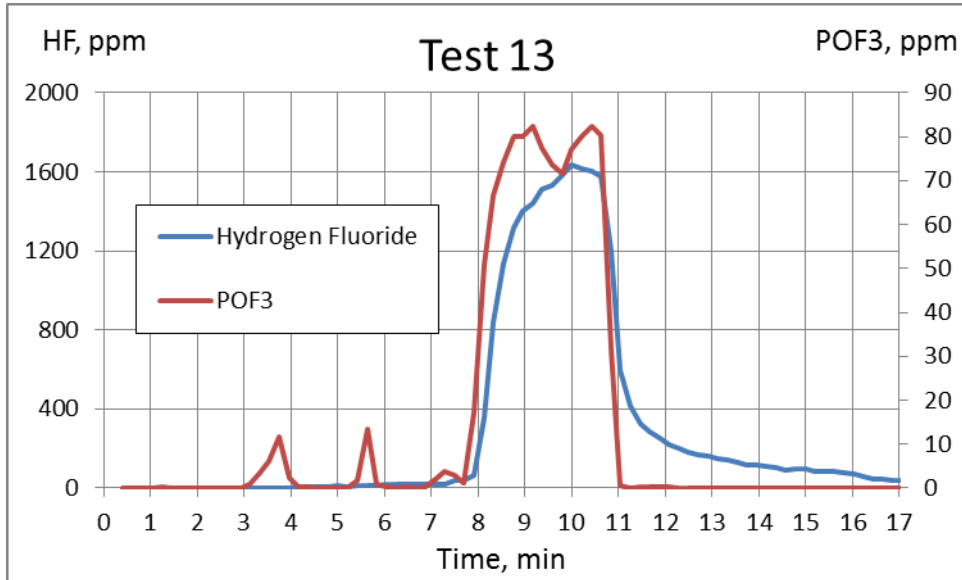

Figure 32 HF and POF₃ concentration as a function of time for test 13. DMC with salt was injected during time 8 to 11 minutes.

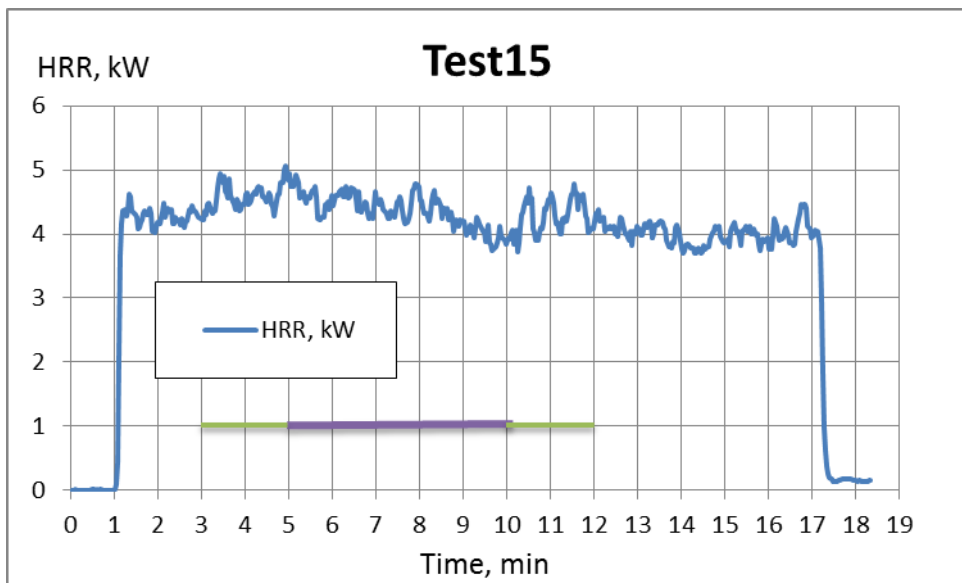

Figure 33 HRR as a function of time for test 15. DMC and salt was inserted through a needle onto a spoon in the flame during time 5 minutes to 10 minutes, DMC only was injected between times 3 and 5 minutes and 10 and 12 minutes.

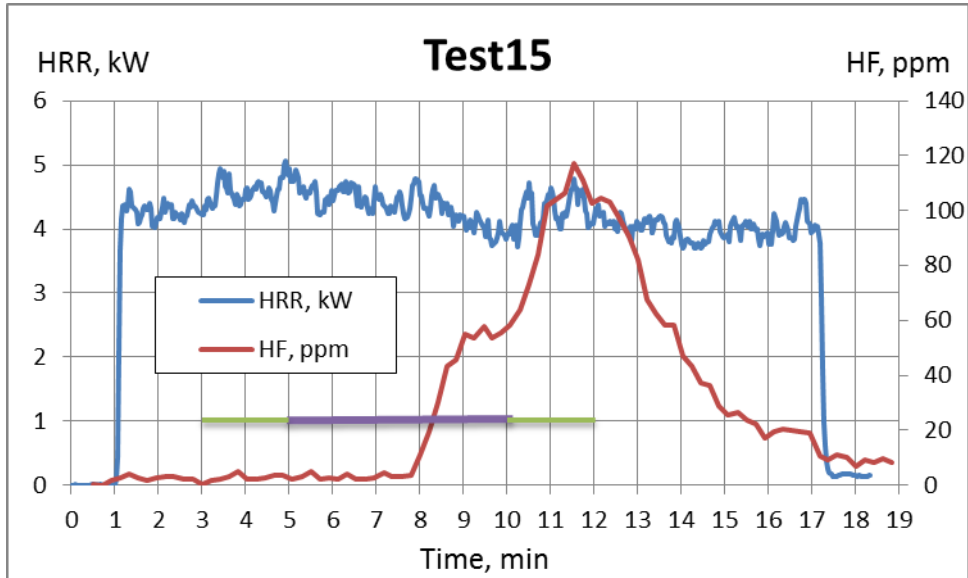

Figure 34 HRR and HF concentration as a function of time for test 15. DMC and salt was inserted through a needle onto a spoon in the flame during time 5 minutes to 10 minutes.

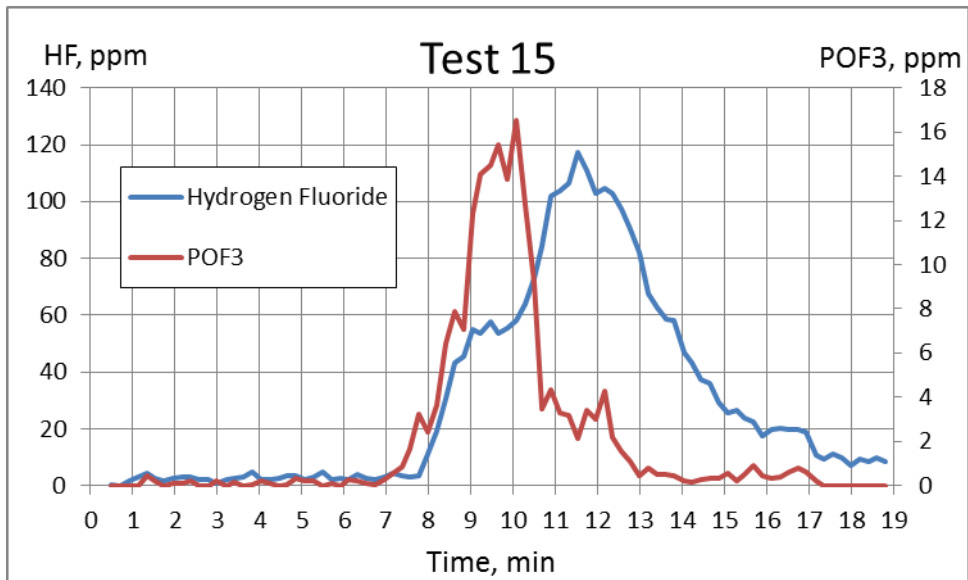

Figure 35 HF and POF₃ concentration as a function of time for Test 15. DMC and salt was inserted through a needle onto a spoon in the flame during time 5 minutes to 10 minutes.

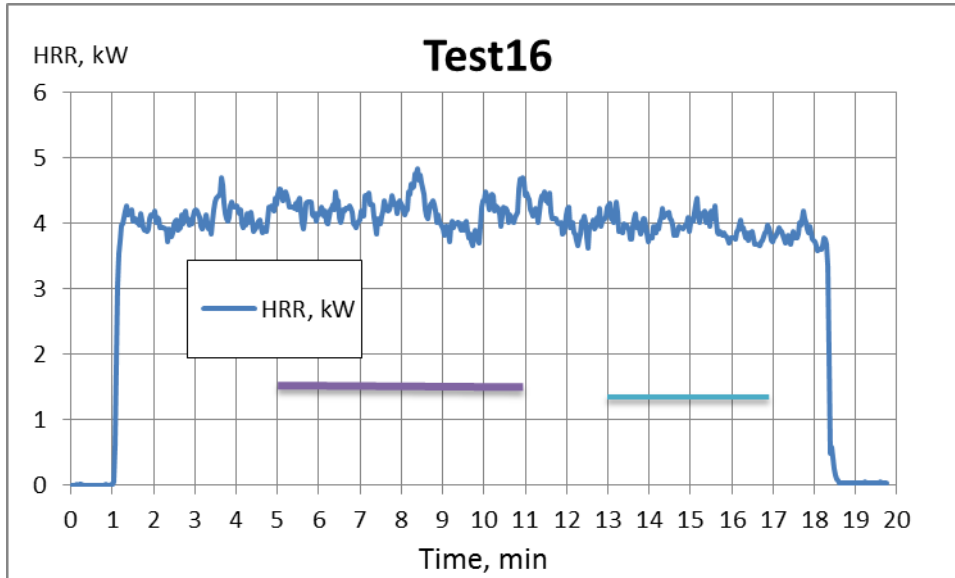

Figure 36 HRR as a function of time for test 16. DME and salt was inserted through a needle onto a spoon in the flame during time 5 minutes to 11 minutes. During time 13 to 17 minutes water was inserted to the spoon instead.

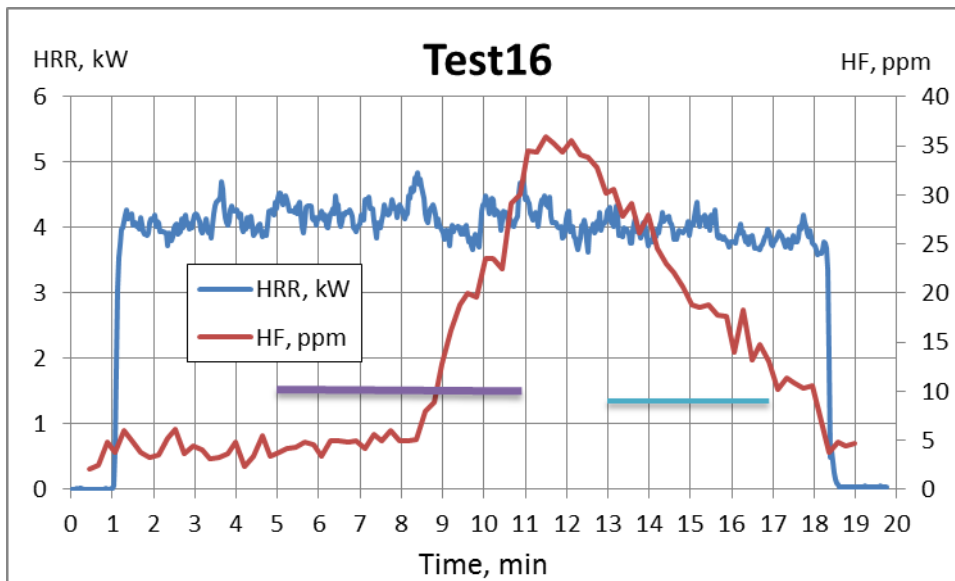

Figure 37 HRR and HF concentration as a function of time for test 16. DME and salt was inserted through a needle onto a spoon in the flame during time 5 minutes to 11 minutes. During time 13 to 17 minutes water was inserted to the spoon instead.

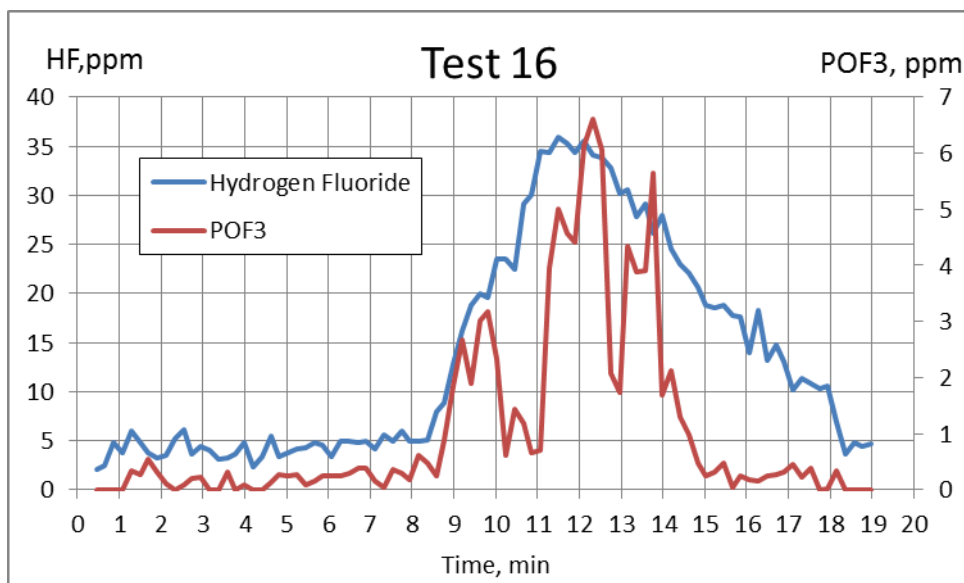

Figure 38 HF and POF₃ concentration as a function of time for Test 16. DME and salt was inserted through a needle onto a spoon in the flame during time 5 minutes to 11 minutes. During time 13 to 17 minutes water was inserted to the spoon instead. Note that the concentration of POF₃ measured here was below the limit of quantification.

The FTIR measurements showed that both HF and POF₃ were always present in the combustion effluents when electrolytes were burning. The measured concentration of HF was always significantly higher than POF₃, often about 20 times higher.

Test 10-16 all shows that the POF₃ seems to appear a bit earlier than HF, this is particular apparent in test 15. It is known that losses of HF occurs in the measurement system and especially in the sampling filter⁵. The effect is most significant at measurements of low concentrations as the proportion captured in the filter in such cases is high compared to the total amount HF sampled through the filter. An effect of HF-losses in the filter is an initial increased response time (until the sampling system is saturated) that can be significant especially in measurements of low concentrations. The filter was exchanged before test 14 but as test 14 was interrupted the filter can be considered as being new for test 15.

Selected filter used in the measurements reported below (test 22-test 27) were analysed for total fluorine content. The analysis results showed that the amounts lost in the filter were low, normally around 5 % on weight basis.

Test results from the second batch of tests are presented in Figure 37 - Figure 53. The result are presented for the tests where solvent and salt was introduced into the flame. For all tests the HRR curve is presented including the HRR from the propane. Different injections are indicated with different colours in the figures, i.e. green for solvent only, purple for salt and solvent, and different blue colours for water and alcohol.

An example of how the flame look liked when salt was injected is given in Figure 39.



Figure 39 Example of flame when electrolyte and salt is injected, test 25

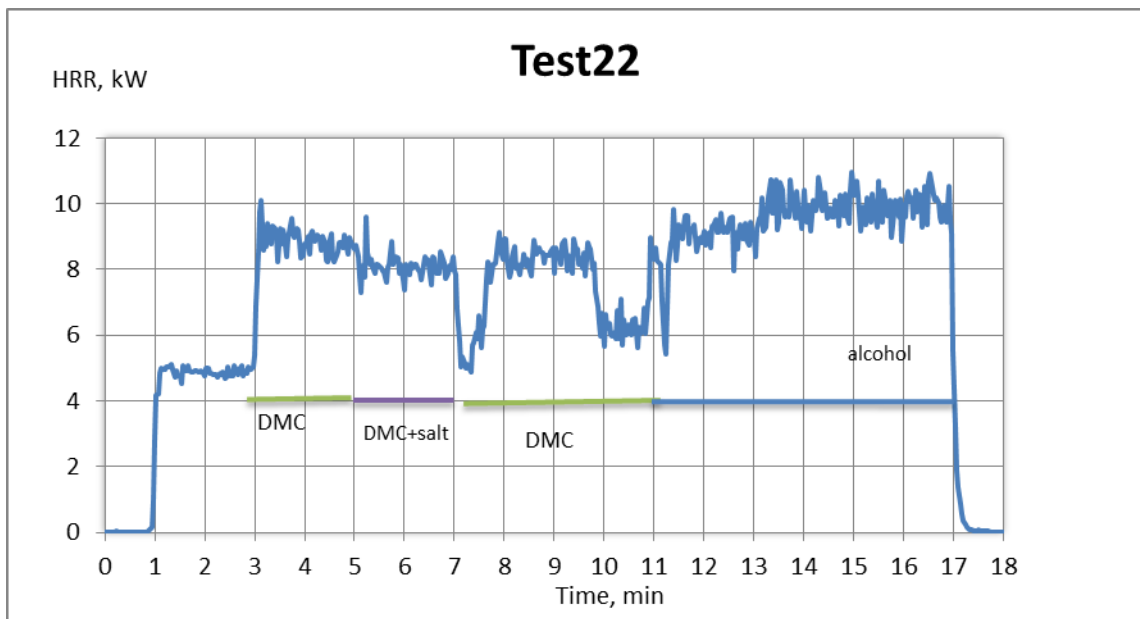

Figure 40 HRR as a function of time for test 22. The different injections period are indicated with a green line for pure DMC, purple line for DMC + salt and a blue line for cleaning with alcohol at the end of the test.

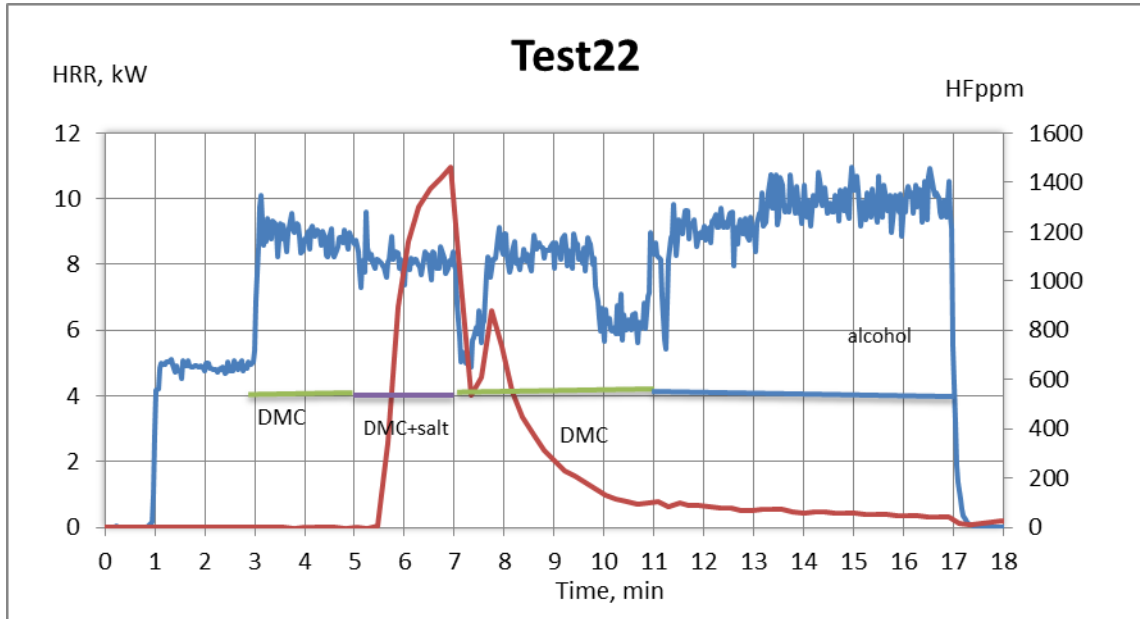

Figure 41 HRR and HF concentration as a function of time for test 22. The different injections period are indicated with a green line for pure DMC, purple line for DMC + salt and a blue line for cleaning with alcohol at the end of the test.

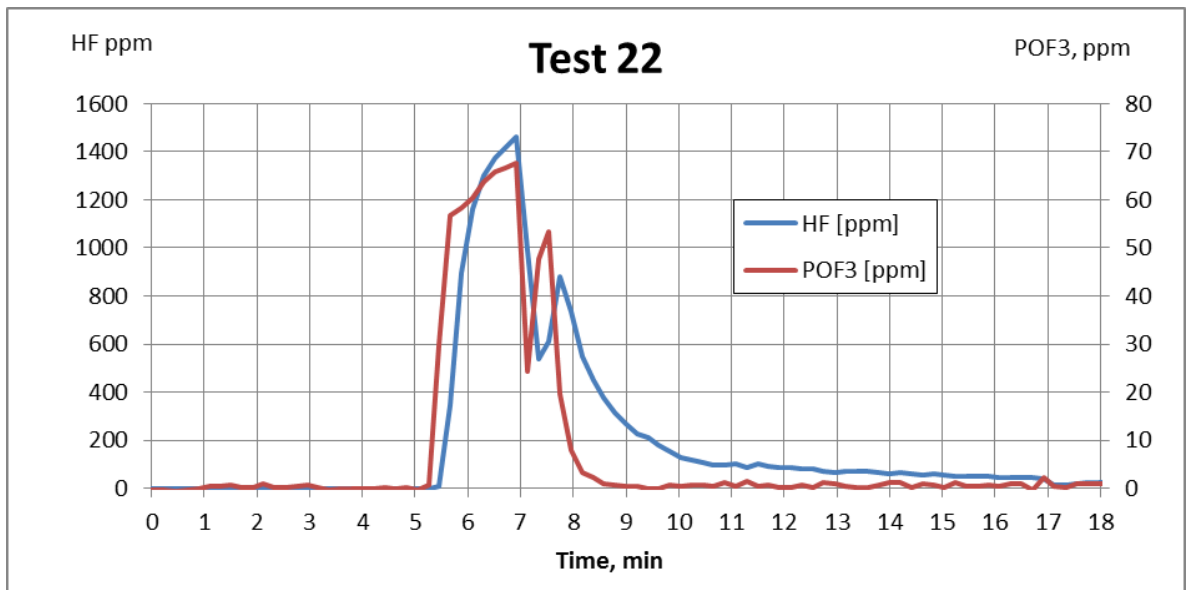

Figure 42 HF and POF₃ concentration as a function of time for test 22. DMC with salt was injected under time 5-7 minutes.

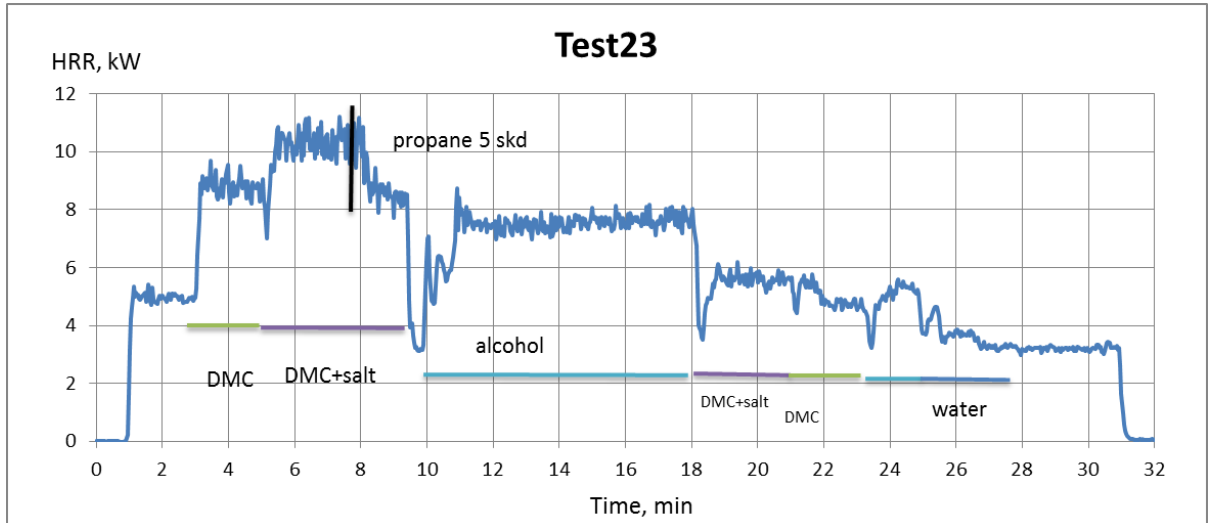

Figure 43 HRR as a function of time for Test 23. The different injections are indicated as green line for DMC only, purple line for DMC with salt (5 minutes until 9:30 and then again 18 until 21 minutes), light blue for alcohol and darker blue for water.

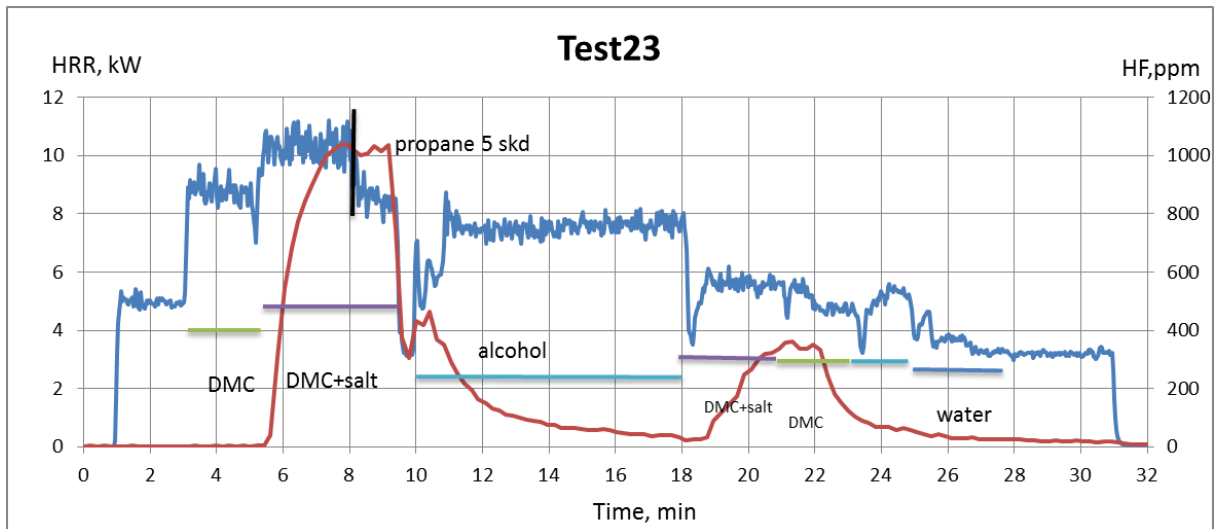

Figure 44 HRR and HF concentration as a function of time for Test 23. The different injections are indicated as green line for DMC only, purple line for DMC with salt, light blue for alcohol and darker blue for water.

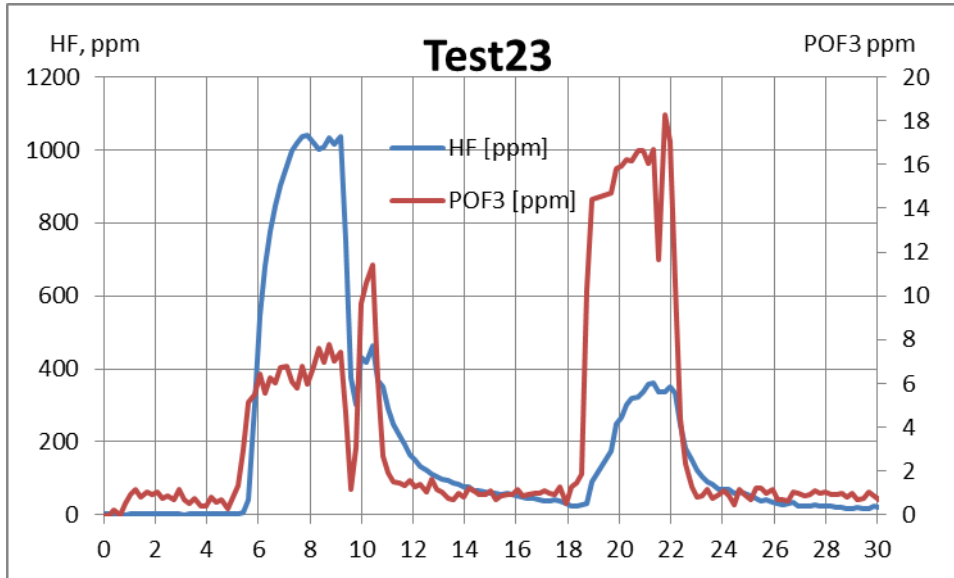

Figure 45 HF and POF_3 concentration in exhaust gases as a function of time for test 23. DMC + salt was injected during time 5 minutes until 9:30 and then again between time 18 and 21 minutes.

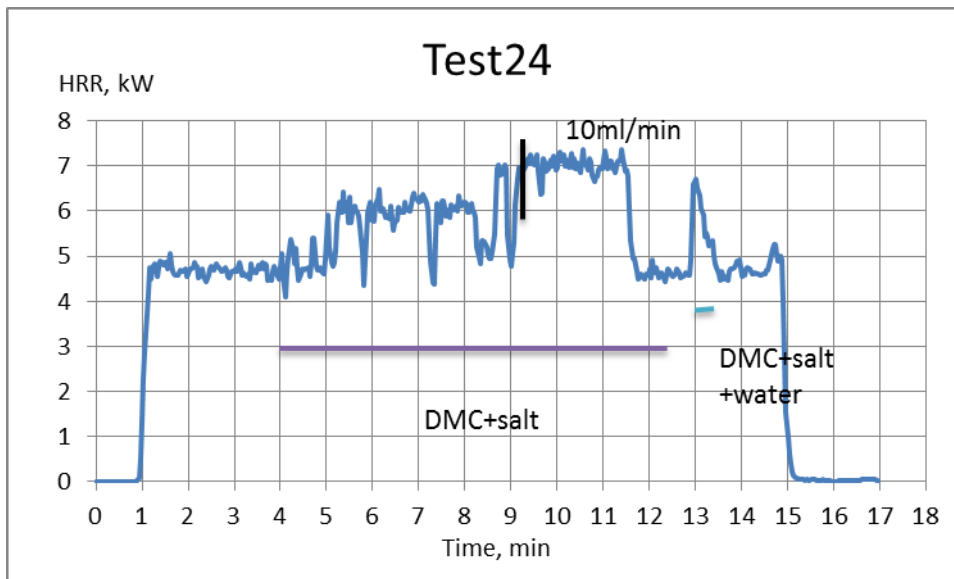

Figure 46 HRR as a function of time for test 24. DMC and salt was injected during time 4 minutes until 12:30, the spray did not work correctly until time 9:15.

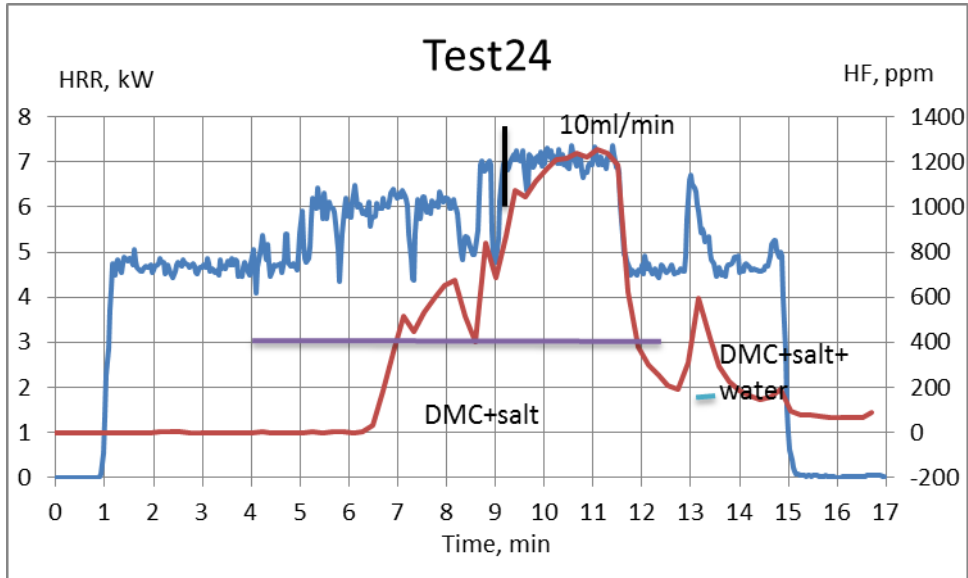

Figure 47 HRR and HF concentration as a function of time for test 24. DMC and salt was injected during time 4 minutes until 12:30, the spray did not work correctly until time 9:15.

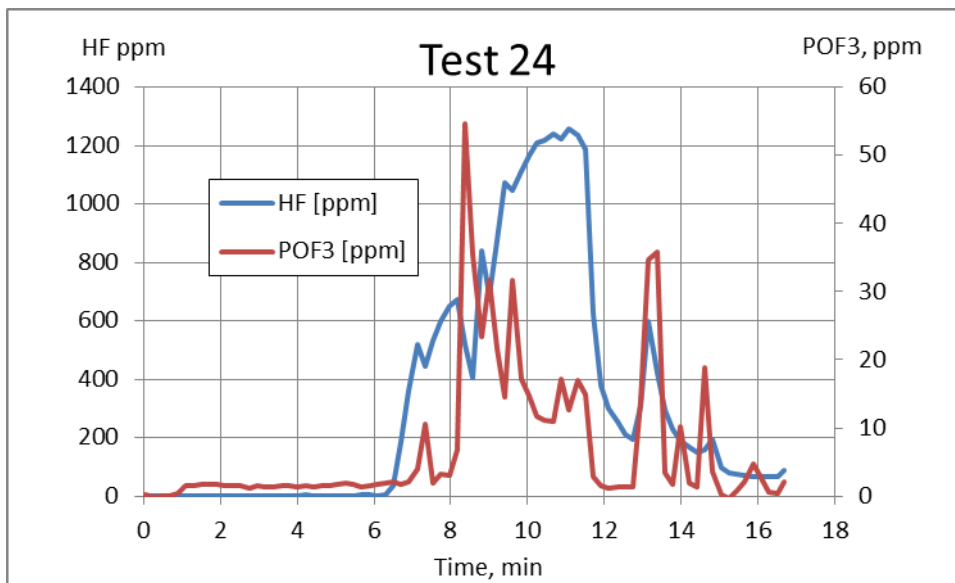

Figure 48 POF_3 and HF concentration as a function of time for test 24. DMC and salt was injected during time 4 minutes until 12:30, the spray did not work correctly until time 9:15.

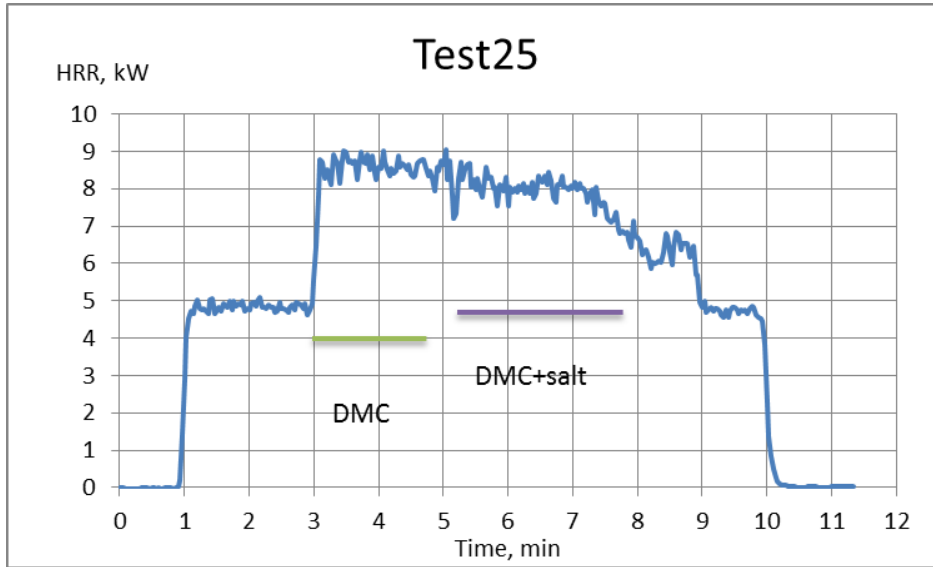

Figure 49 HRR as a function of time for test 25.

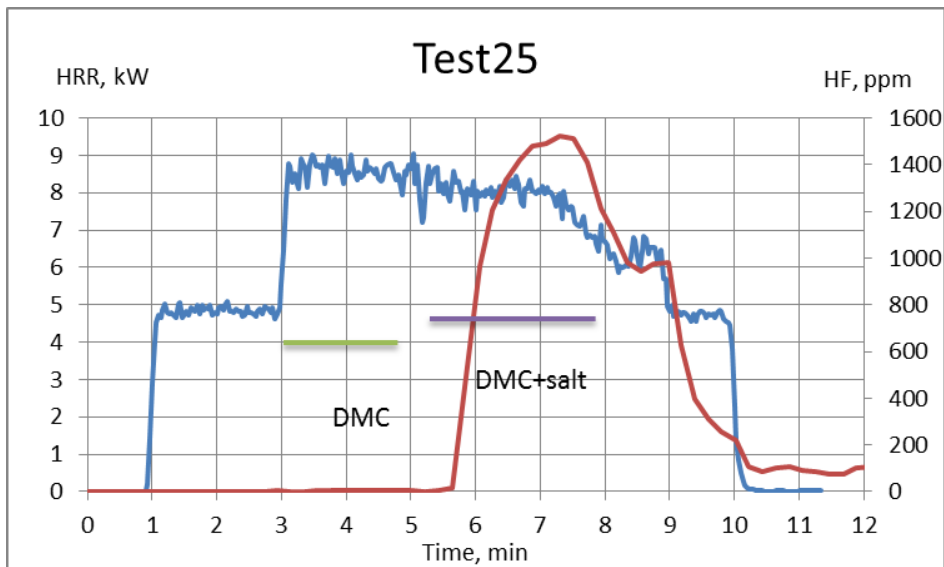

Figure 50 HRR and HF concentration as a function of time for test 25.

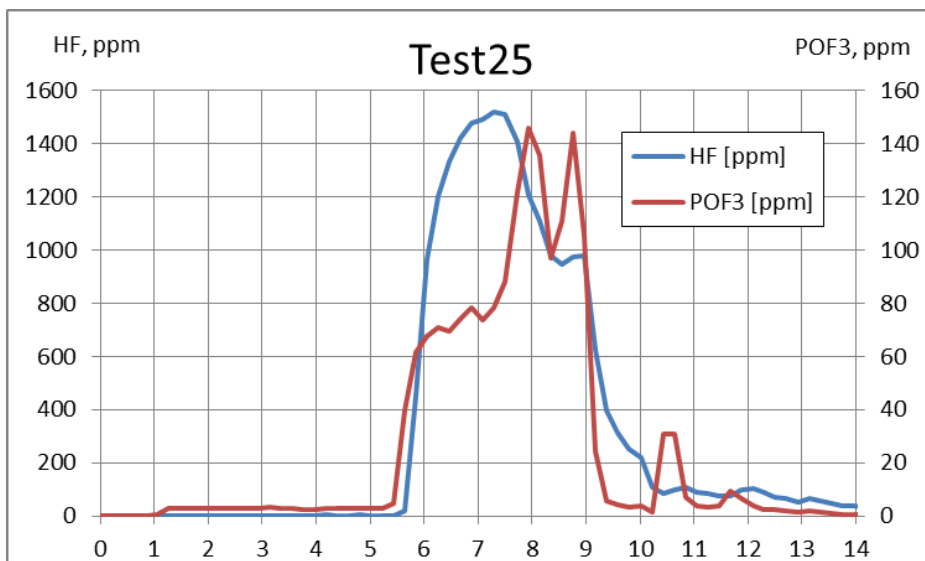

Figure 51 HF and POF₃ concentration as a function of time for test 25.

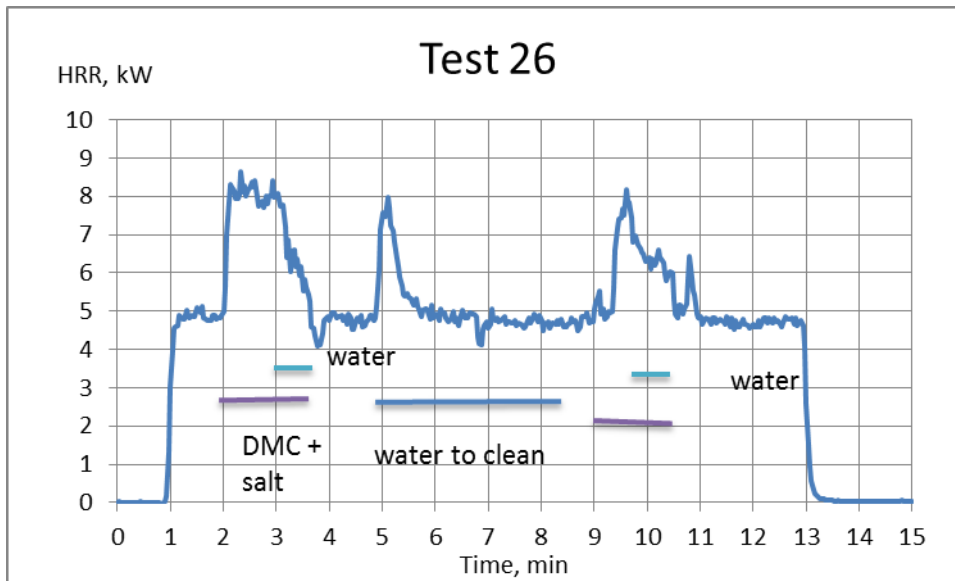

Figure 52 HRR as a function of time for test 26. DMC and salt injection indicated as purple line at time 2 until 3:40 and then at time 9 minutes until 10:30. Water injection into flames by water spray bottle indicated as light blue line from time 3 minutes until 3:40 and then from time 9:50 until time 10:30. Water was injected through the needle between time 5 minutes and 8:30 to clean the system.

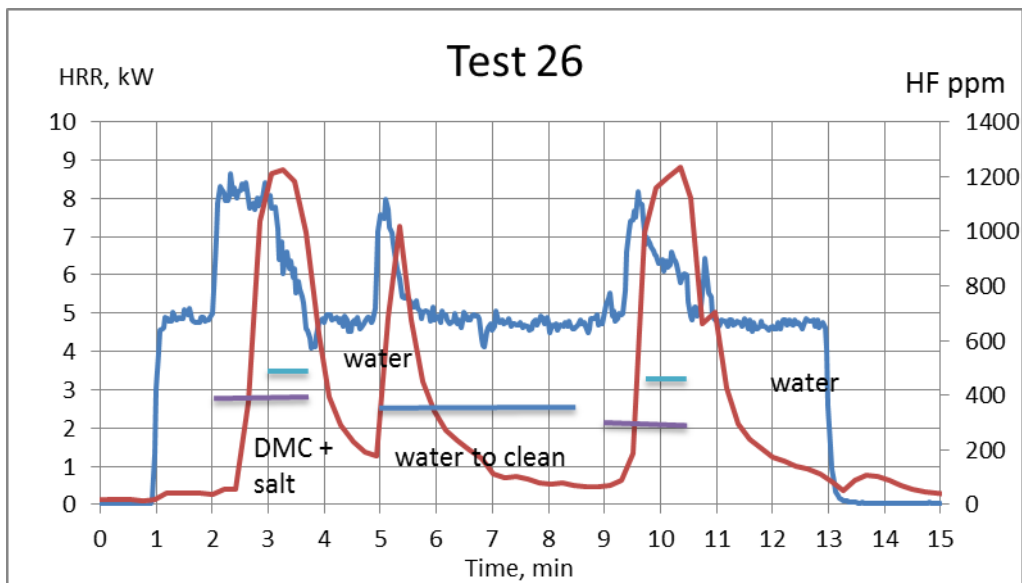

Figure 53 HRR and HF concentration as a function of time for test 26. DMC and salt injection indicated as purple line at time 2 until 3:40 and then at time 9 minutes until 10:30. Water injection into flames by water spray bottle indicated as light blue line from time 3 minutes until 3:40 and then from time 9:50 until time 10:30. Water was injected through the needle between time 5 minutes and 8:30 to clean the system.

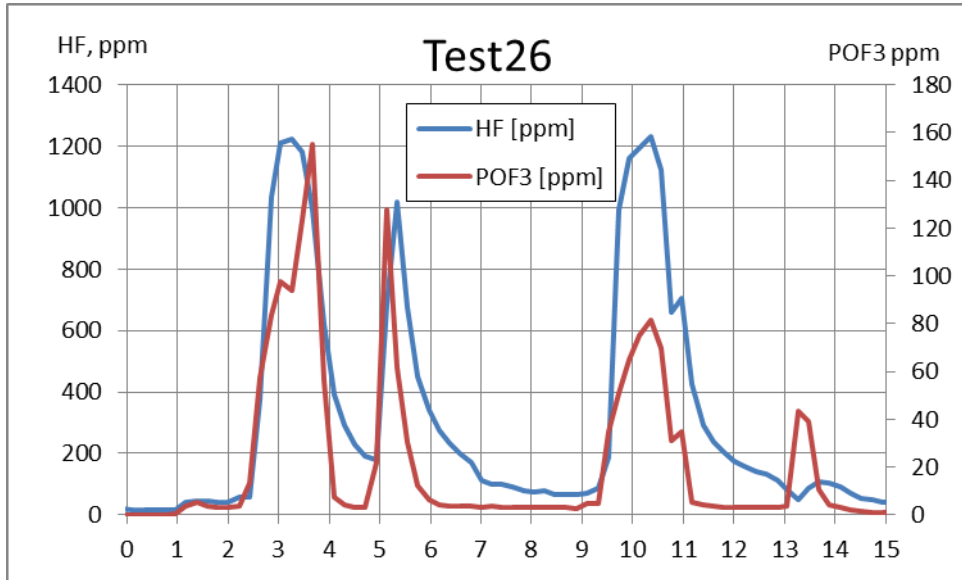

Figure 54 HF and POF₃ concentration as a function of time for test 26.

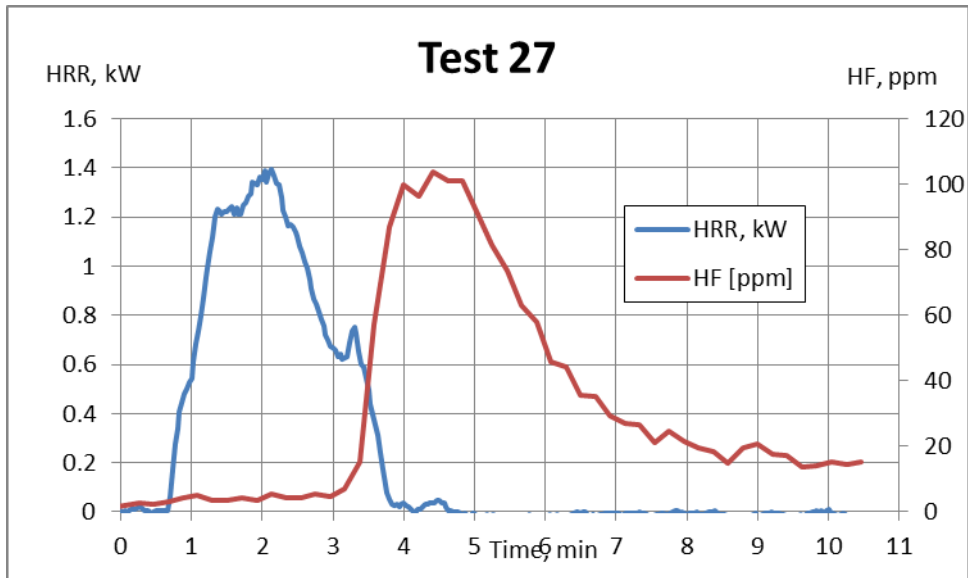

Figure 55 HRR and HF concentration for the cakecup test. Heat radiation applied 10-15 kW/m². Ignited about 15 s after heat application started.

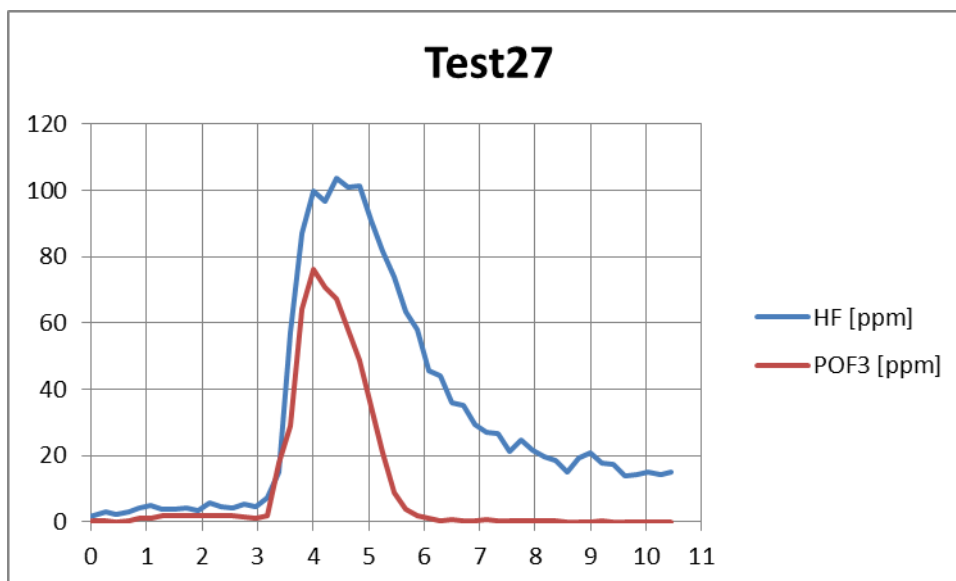

Figure 56 HF and POF₃ concentration as a function of time for test 27, test where the electrolyte was heated in a cakecup and ignited by a igniter.

Test 27 shows a different behaviour than the other tests. Unfortunately there was no electrolyte available to explore this further as this was the last test. This could indicate a potential for that toxic gases are produced especially at the end of a fire. This could also reflect that the salt is burnt later than the electrolyte solvent.

The test results from the burner tests in the second batch are summarized in Table 6. The table contains the amount of salt injected expressed as mass of F (grams) based on pump speed, Molar concentration of solution and time sprayed into the flame. This value contains some uncertainty due to uncertainties in conjunction with the pumps and the fact that the spray was not always a spray but more of a beam. The gases produced are expressed as the amount HF and POF₃ in grams, these values are then recalculated into mass of F in grams. The HF values contain also the fluorine content found in the filters analysed after the tests. This value was added to the HF content despite we do not know whether the fluorine is in the form of HF or any other fluorine specie.

Table 6 Results from tests conducted in second batch.

Test nr	Amount salt injected as F (g)	Amount HF (g)	Amount POF ₃ (g)	Amount HF as F (g)	Amount POF ₃ as F (g)	Missing F (g)	HF/POF ₃ by mass
22	3.4	2.5	0.5	2.3	0.3	0.8	5
23a	3.1	2.8	0.1	2.6	0.1	0.4	23
23b	1.7	0.8	0.2	0.8	0.1	0.8	4
	HRR compensated 0.9	0.8	0.2	0.8	0.1	0.0	4
24	3.4	4.2	0.5	4.0	0.3	-0.9	8
25	6.3	3.7	1.4	3.5	0.8	2.0	3
26a	4.0	1.4	0.6	1.3	0.3	2.3	2
26b	Cleaning system with water	0.8	0.3	0.7	0.1	-0.8	
26c	1.7	1.6	0.4	1.5	0.2	0.0	4

The results in Table 6 shows that not all F is captured in the measurements. This can be due to that some of the F is not present as HF or POF₃ but some other species such as phosphoric acid. We see also that we over-predict the amount of F in two cases, one case where the system was not injected with salt, this was probably due to some remains of salt in the pumps or the filters used to protect the needles from clogging. And one case where time was spent in the beginning of the test to get the spray working with salt. The response time of the FTIR analysis makes it difficult to exclude this initial amount of salt into the system in the calculations unfortunately.

6 Fire tests with batteries

Tests were also conducted on battery cells and batteries used for automotive applications and laptops. Water was added to the flames in one test in order to investigate the influence of water addition to the HF production.

6.1 Batteries tested

The cells in test 1-5 were commercially available pouch cells for automotive applications. The cell is a power optimized cell with a cathode chemistry of LiFePO_4 , lithium ion phosphate (commonly abbreviated LFP).

The cells in test 6 were commercially available cylindrical cells (of type 26650). The cell is an energy optimized type of LFP, and have been used in e.g. electric vehicles.

The laptop battery pack in test 7 consisted of 2 commercially available battery packs for laptops. Each laptop pack consisted of 6 cells, in which 3 were in series and 2 in parallel, often denoted as 3s2p. The laptop battery pack differs from the other tested cells in several aspects. Firstly, it has a different Li-ion chemistry, which has a higher nominal cell voltage (3.7 V vs 3.2 V for LFP). Secondly, it is a commercially complete battery pack including electronics, plastic housing, electrical connector to laptop, etc. Thirdly, it has a higher pack voltage due to the fact that three cells are connected in series inside the battery pack, increasing the voltage by a factor 3 (to 11.1 V).

All cells were unused. However, the laptop pack was less than 6 months old. The LFP type 1 cells used in tests 1-5 were approximately 1-2 years old and the LFP type 2 cells in test 6 were approximately 2-3 years old.

Table 7 Fire tests with batteries conducted under the hood of the SBI-equipment.

Test no	Cell type	State of Charge, SOC (%)	Nominal capacity (Ah)	No of cells	Total weight (g)
1	LFP type 1, pouch	100 %	35 Ah	5	1 227.9
2	LFP type 1, pouch	100 %	35 Ah	5	1 229.7
3	LFP type 1, pouch	100 %	35 Ah	5	1 229.3
4	LFP type 1, pouch	0 %	35 Ah	5	1 228.6
5	LFP type 1, pouch	50 %	35 Ah	5	1 227.6
6	LFP type 2, cylindrical	100 %	28.8 Ah	9	734.8
7	Laptop battery pack	100 %	33.6 Ah*	2 x (3x2)	639.0

* Corresponding value, rated at each battery pack is 5.6 Ah with 11.1 V.

6.1.1 Cell preparation

All battery cells were charged/discharged to the selected state of charge (SOC) level, using an ordinary power aggregate for labs as well as Digatron battery test equipment. The laptop batteries were fully charged by putting them into a laptop computer.

The five cells, in tests 1-5, were carefully fastened together with steel wire. The poles (tabs) were cut on all cells but one.

The cells in test 6 had originally welded tabs on its poles which after charging were physically removed. The nine cells were placed inside a box, which had steel net at the bottom and top and walls made of a silica board. These specifications were safety precautions in order to avoid possible projectiles.

The laptop pack, which consisted of two identical laptop packs were placed inside a steel net and fastened on the burner grid in order to prevent possible projectiles.

6.2 Experimental apparatus

The tests were conducted in the Single Burning Item apparatus, EN13823, that is normally used for classification of building materials according to the European Classification scheme. This apparatus was chosen as it has a suitable extraction flow for the tests conducted.

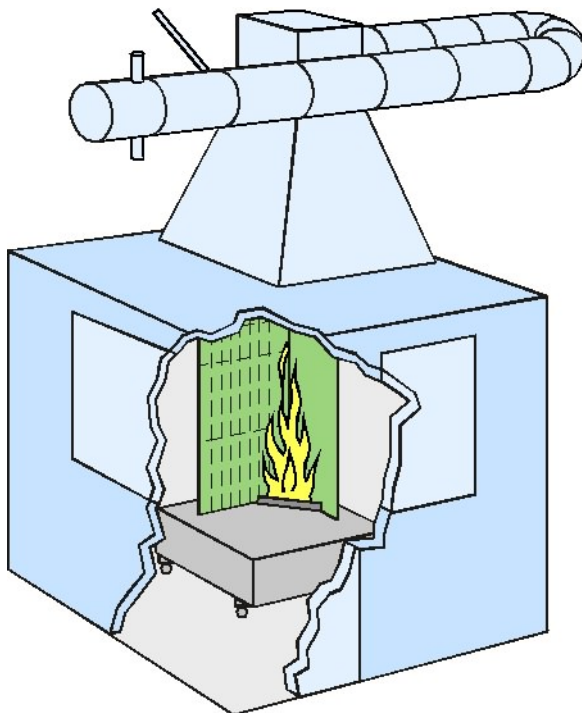

Figure 57 The SBI apparatus.

The cells or batteries were placed on a small table with the table top consisting of wires. A propane burner was placed underneath the batteries/cells.



Figure 58 Experimental set-up test 1-5.



Figure 59 Experimental set-up test 6.



Figure 60 Experimental set-up test 7.

6.3 Experimental procedure

In all tests a premeasuring time of 5 minutes was used for the HRR before the gas supply to the burner was turned on. All tests were video-recorded, video recordings started 1 minute before the burner. FTIR measurements started 2 minutes before the burner. The tests were conducted over two days with tests 1-5 the first day and tests 6-7 the second day. Both days started with a blank test where only the burner was used and HRR and FTIR gases were measured. The HRR from the burner was 14-15 kW. The burner HRR was subtracted from the results.

6.4 Results

In tests 1-3 outbursts of rapid vented gases could be seen. In principle there was one outburst per cell in tests 1-3 with had 100% SOC. In tests 4-5 with lower SOC, no outbursts could be observed. Outbursts could be seen in tests 6-7. The laptop battery pack in test 7 showed rapid venting in several directions and probably had the most energized venting of the seven tests.

In the seven tests, the orientation of the cells were different due to the different battery types (pouch, cylindrical, complete pack). This could potentially have affected the results, since some gases might have been missed by the hood collecting the gases. Also the extent to which gases are mixed in a limited space could have an impact on the results. It was not possible to determine the magnitude of these aspects in these tests. The cells in tests 1-5 were however all oriented which provide for a good comparison between these tests. The other two tests can be considered more as examples of possible scenarios.

All tests were photographed. Photos can be found in appendix C.

6.4.1 Video

All tests were captured on video. Below is the comment to the post-analysis of those videos. Note that the “video time” is 1 minute after the reference time. In other words, the

reference time 01:00 corresponds to 00:00 in video time. Video time is used in the tables below.

Table 8 Comment to test 1 from video analyses.

Video time (min:sec)	Comment
00:00	Video start
01:20	LPG fire beginnings
02:05	Cell material/vented material is clearly started to burn on the long sides
02:42-57	Outburst 1, 2 angles: ~ 45,100 deg Lighter flame colors (real or due to camera)
05:41-49	Outburst 2
05:53-04	Outburst 3, large flame on the right side from 110-190 deg
06:04-06:49	Venting flame at left side, burning for a relative long time
06:49-59	Outburst 4
07:34-40	Outburst 5
18:25	LPG flames end

Table 9 Comment to test 2 from video analyses.

Video time (min:sec)	Comment
00:00	Video start
01:05	LPG fire beginnings
02:13-19	Outburst 1
02:20-03:11	Burning
05:26-35	Outburst 2, 3 angles: ~ 0 (little), 80 (more), 120(more) deg
05:56-01	Outburst 3
06:01	Maybe an smaller outburst
06:29-41	Outburst 4 (3 angles as above in No.2)
07:06-17	Outburst 5
18:07	LPG flames end

Table 10 Comment to test 3 from video analyses.

Video time (min:sec)	Comment
00:00	Video start
01:10	LPG fire beginnings
02:04-12:06	Outburst 1 (left side 45deg, right side 120 deg (most @ right))
02:31-40	Some smoke from back of cell pack
03:05-09	Outburst 2 (both left and right side)
	More smoke from back of cell pack
05:50-02	Outburst 3 (most on left side, left ~30 deg, right ~ 145 deg) Lighter white-orange color than LPG flame colors
06:24-44	Outburst 4 (most left side, ~40 deg) Incl darker smoke
06:44 – 07:00	Clear cell fire along the long-sides, incl darker smoke
> 07:00	Person with handheld water mist makes entrance
07:13-07:23	Smaller outburst 5 (most left side)
07:41-07:53	Smaller outburst 6 (both sides)
07:40	Water mist on Pulsed by hand (~1 sec per puls) In flames above cell (cell is primarily not touched)
09:02-09:12	No water mist applied during this time, might have been longer time period
~ 09:45	Water mist off
11:15-56	Water mist on, into flames above cell
12:02-30	Water mist on, onto cell
12:43-44	Water mist on, onto cell, one pulse
13:45 – 14:03	Water mist on, into flames above cell
18:10	LPG flames end

Table 11 Comment to test 4 from video analyses.

Video time (min:sec)	Comment
00:00	Video start
01:15	LPG fire beginnings
	No outbursts could be seen
33:22	LPG flames end

Table 12 Comment to test 5 from video analyses.

Video time (min:sec)	Comment
00:00	Video start
01:12	LPG fire beginnings
	No outbursts could be seen
28:04	LPG flames end

Table 13 Comment to test 6 from video analyses.

Video time (min:sec)	Comment
00:00	Video start
01:20	LPG fire beginnings
05:56	Outburst 1 fast (max 0,5 sec), straight upwards
05:57-09	Probably cell venting which is burning
06:13-14	Outburst 2 little longer (0,5-1 sec), straight upwards
06:19-20	Outburst (0,5 sec), straight upwards
06:20-06:40	Probably burning from cell vent
06:46-47	Outburst 3 (1 sec), straight upwards
06:47-55	Burning from cell vent
06:58	Probably burning from cell vent
07:14	Outburst 4, straight upwards
07:14-07:24	Burning from cells
07:24	Outburst 5 very rapidly (~ 100 ms), straight upwards
07:26->	Outburst 6, straight upwards Burning and outburst, ventilation, a lot of activity, hard to
07:26:07:41	Burning over complete battery pack
07:41	Outburst 7 very rapidly, straight upwards
07:41-08:01	Burning from cells
08:01	Outburst 8 very rapidly, straight upwards
08:13	Outburst 9, not straight upwards but upwards to the right
08:15/16	Maybe outburst
08:18	Clear outburst 10 (1 sec), not straight upwards but upwards to the left
08:28	Outburst 11 , straight upwards
08:41-50	Clear outburst 12 (9 sec), not straight upwards but upwards to the left
08:45-53	Maybe outburst 13, long, straight upwards-little right
~07:00 - 10:00	Fire from battery cells (pack) almost finished at 10:00
10:00-12:45	Some flames from time to time, some black smoke
12:45-18:32	Less intense than above, and from time to time: some flames from time to time, some black smoke
18:32	LPG flames end

Table 14 Comment to test 7 from video analyses.

Video time (min:sec)	Comment
00:00	Video start
01:20	LPG fire beginnings
02:25	Small fire in left pack, likely in plastics – yellow flames (same as LPG flames)
03:24	One short flame
03:33	One short flame
03:34-39	Outburst 1 (4-5 sec)
03:43	One short flame
03:46-48	Outburst 2 (2-3 sec)
03:54	One short flame
03:58-01	Outburst 3 (2-3 sec)
04:04-08	Outburst 4 (3-4 sec)
04:12-14	Outburst 5 (2-3 sec)
04:15-19	Outburst 6 (4 sec), maybe several
04:22-23	Outburst 7 (2 sec), can have been multiple, last 20 sec
04:35-38	Outburst 8 (2-3 sec)
04:56-57	Outburst 9 (1 sec)
05:02-03	Outburst 10 (1 sec)
> 06:00	Light smoke
06:50-07:00	10 sec white smoke
> 07:00	Light smoke
18:14	LPG flames end

6.4.2 HRR and gas measurements

The results from the HRR measurements are summarized in Table 15. The HRR curves are presented in Figure 58 for test 1, 2 and 3, Figure 61 for test 4 and 5 and Figure 62 for test 6 and 7 respectively. Figure 59 indicates when outbursts of gases could be observed from the video while Figure 60 shows the HRR results from test 3 together with indications of when water mist was sprayed into the flames. Even if the maximum HRR was about the same for test 1, 2, 3 and 7, the test performance was quite different with large flames and material sprouting out from the laptop cells.

Table 15 Summary of results from the fire tests.

Test no	Weight loss (g)	Max heat release (kW)	Total heat release (kJ)
1	346	48	6826
2	342	44	6645
3	341	42	7130
4	353	9.5	7356
5	354	14	7460
6	145	26	2409
7	258	50	3036

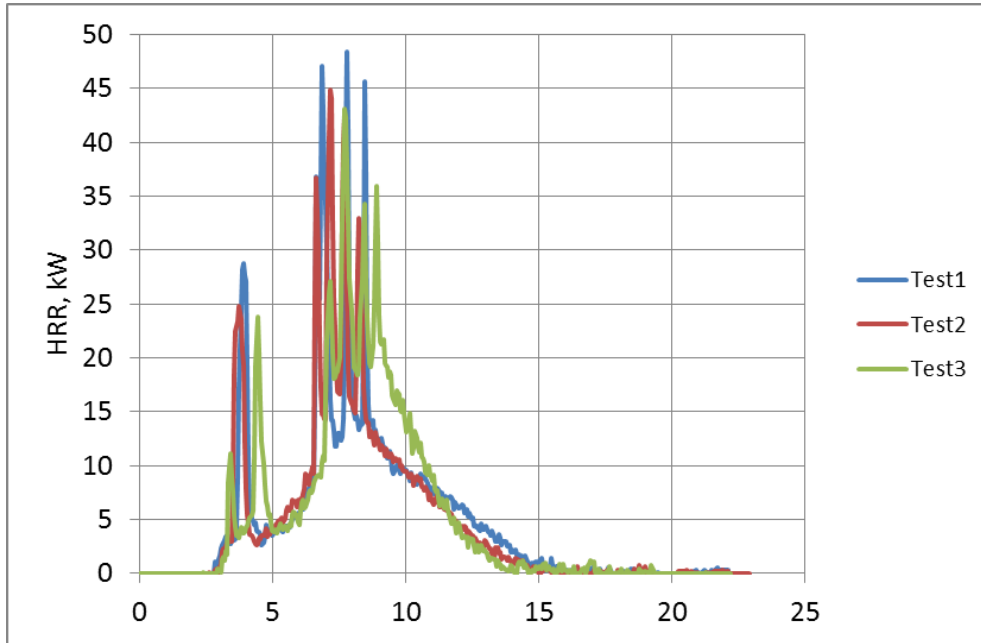

Figure 61 HRR measurements from test 1-3.

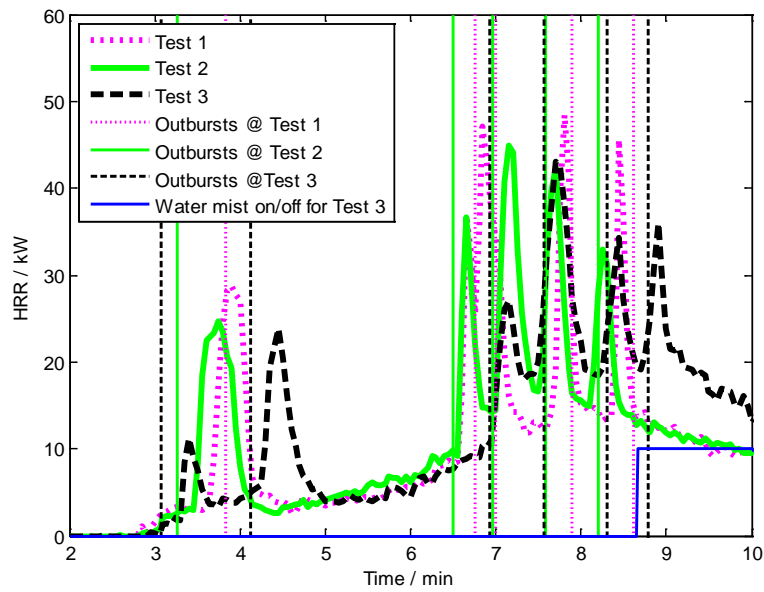

Figure 62 HRR measurements with outbursts as noted in the videos marked together with water mist injection for test 3.

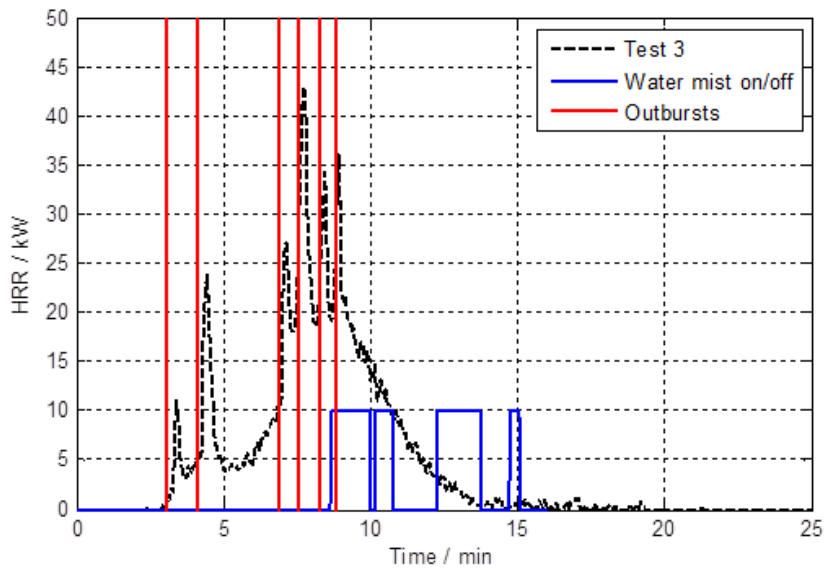

Figure 63 Water mist injection for test 3.

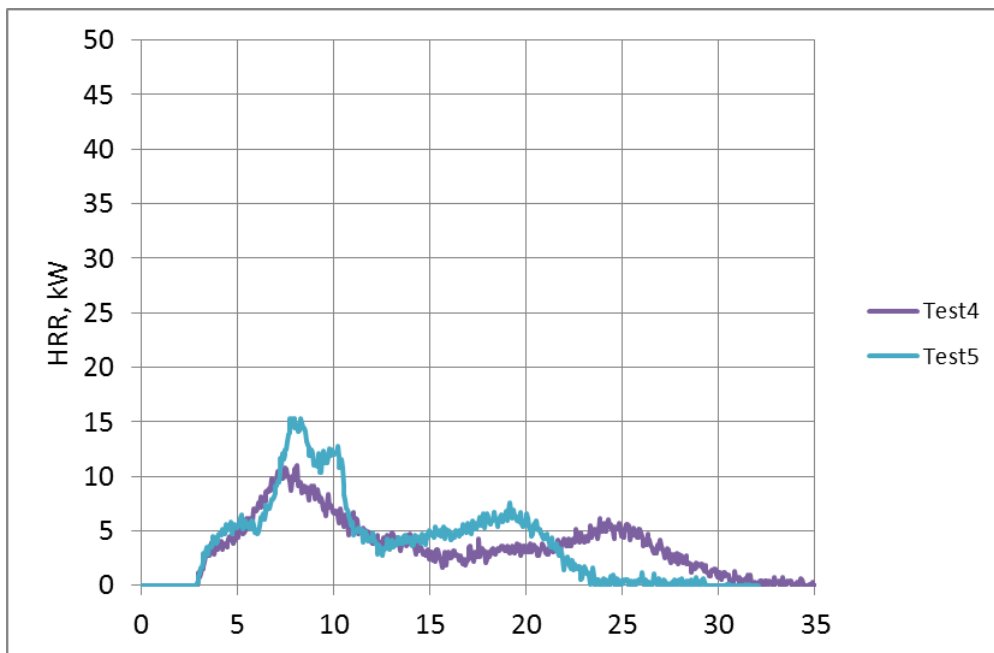

Figure 64 HRR measurements from test 4-5.

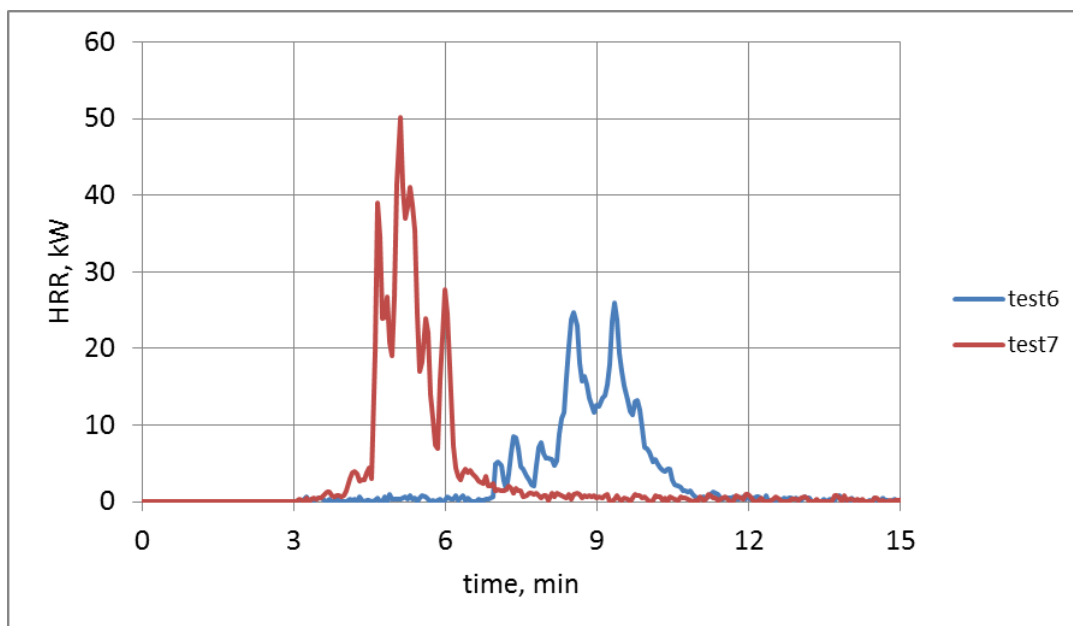

Figure 65 HRR measurements from test 6 and 7.

The FTIR measurements show production of HF in all tests, but POF_3 could not be detected. The measured concentrations of HF were generally quite low but well above the detection limits. Maximum concentrations in tests 1-2 were about 15 ppm and the duct flow was decreased before remaining tests to increase the HF concentration in the duct. The maximum concentration in the remaining tests were in the range 30 - 50 ppm.

The high dilution in the exhaust duct means that POF_3 might have been produced but not detected by the FTIR. Assuming that the ratio between HF and POF_3 concentration was 20 as seen in the spray-tests with the cone calorimeter, that would correspond with maximum POF_3 -concentrations below 1 ppm in tests 1-2 and 2.5 ppm in tests 3-5 which is below the quantification limit (6 ppm) for the FTIR.

The amount of HF produced during tests 1-5 is presented in Table 16. It is clear that the low concentration of HF resulted in a very large relative loss of HF in the sampling filters. In addition is the HF production presented together with the HRR in Figure 65- Figure 69 for test 1-5. The delay of HF compared to HRR seen in the production curves below is most probably influenced by retention in the filter. More results can be found in Appendix B.

From Table 15 it is evident that the total amount of HF produced is lower for the fully charged cells than those cells with a lower SOC. This could be due to the rapid outbursts of gases during these tests so that parts of the gases might not have been collected, but as the Total Heat Release (THR) from the tests are in the same order of magnitude then it seems that most of the gases were captured. Alternatively, the prolonged fire duration allowed more HF to be produced as it might give a chance for a more complete burning, or else it has something to do with how the Fluorine is available in the battery at different SOCs. It has not been possible to explore this further at this stage.

Table 15 also show that despite the larger peak in production rate of HF in test 3 where water was introduced into the flame, the total amount of HF was still the same.

Table 16 Results of HF analysis with FTIR from test 1-5.

Test no	Max production rate (g/s)	Total amounts from FTIR (g)	Total amounts from filter (g)	Total amounts (g)	Total yields (mg/g)
1	0.0088	3.2	1.7	4.9	14
2	0.0077	3.9	2.4	6.3	18
3	0.0154	4.2	1.5	5.7	17
4	0.0102	9.7	1.6	11.3	32
5	0.0164	12.0	1.9	13.9	39

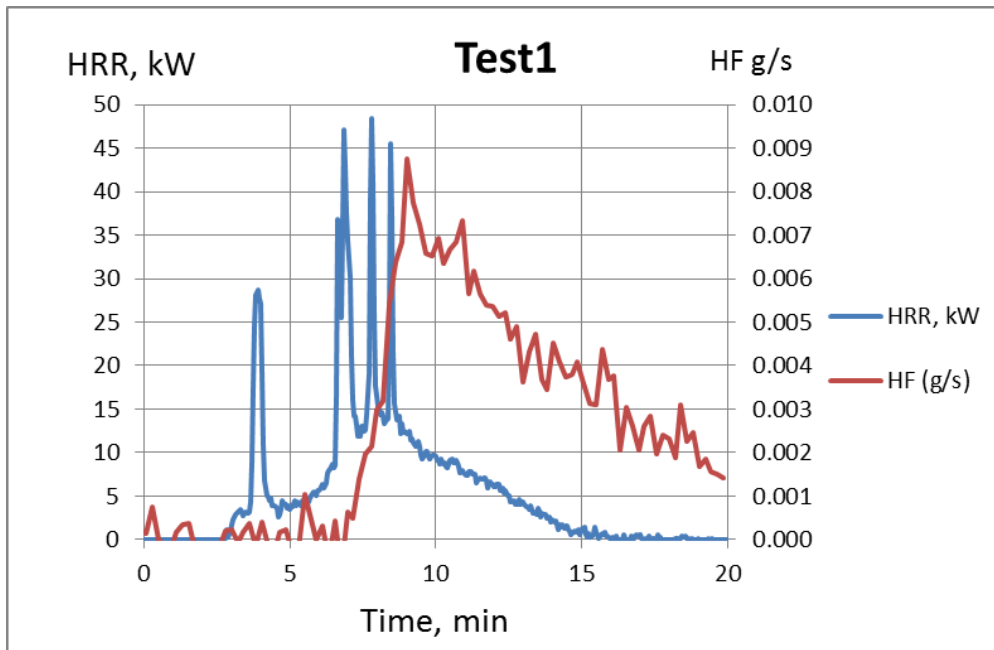

Figure 66 HRR and HF production as a function of time for test 1. The HF production only includes the readout from the FTIR so HF that is captured in the filter is not included.

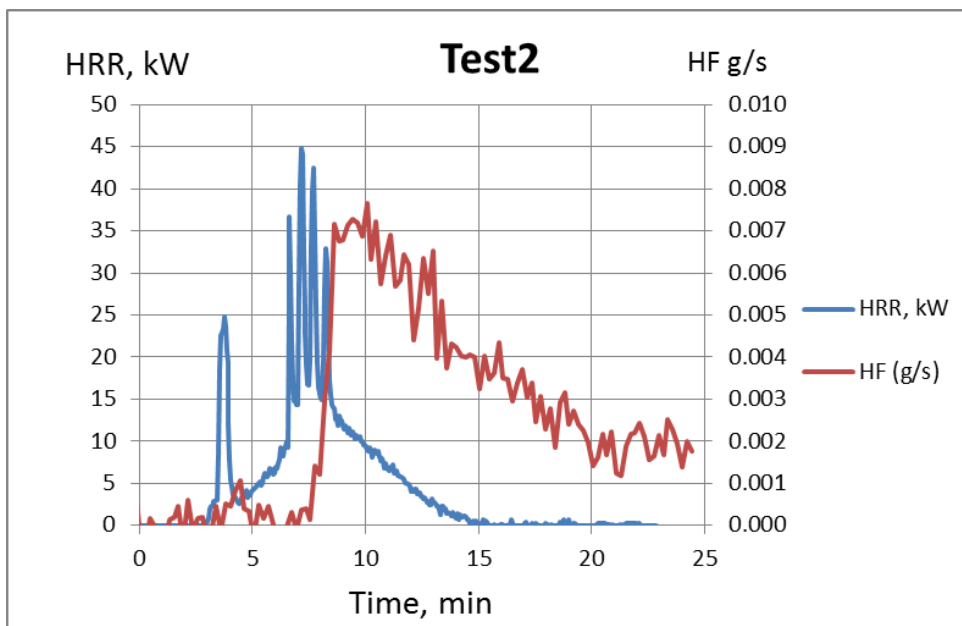

Figure 67 HRR and HF production as a function of time for test 2. The HF production only includes the readout from the FTIR so HF that is captured in the filter is not included.

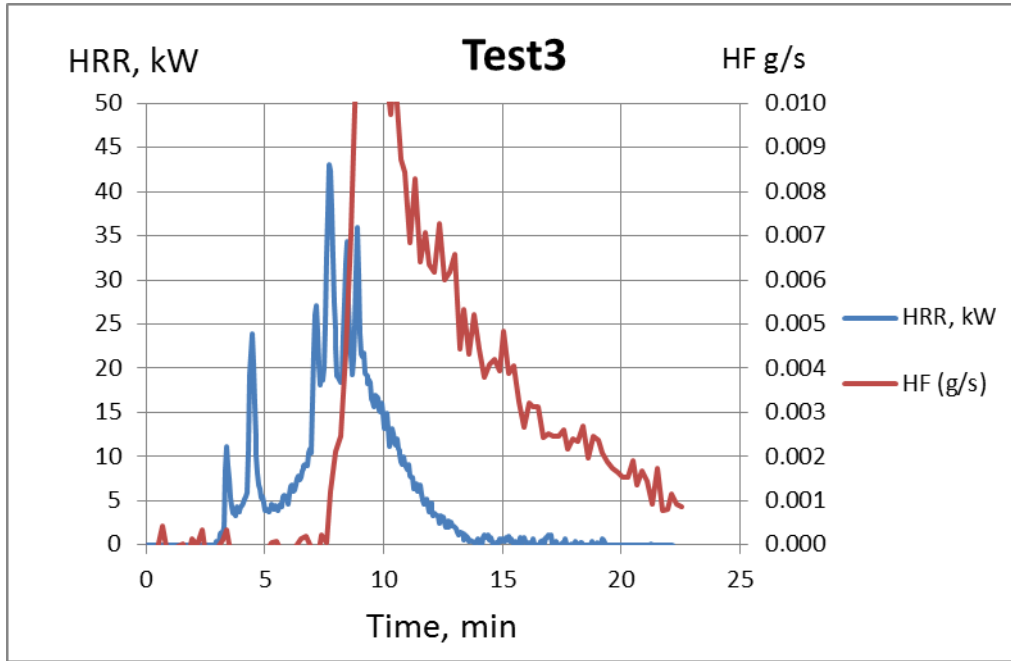

Figure 68 HRR and HF production as a function of time for test 3. The HF production only includes the readout from the FTIR so HF that is captured in the filter is not included.

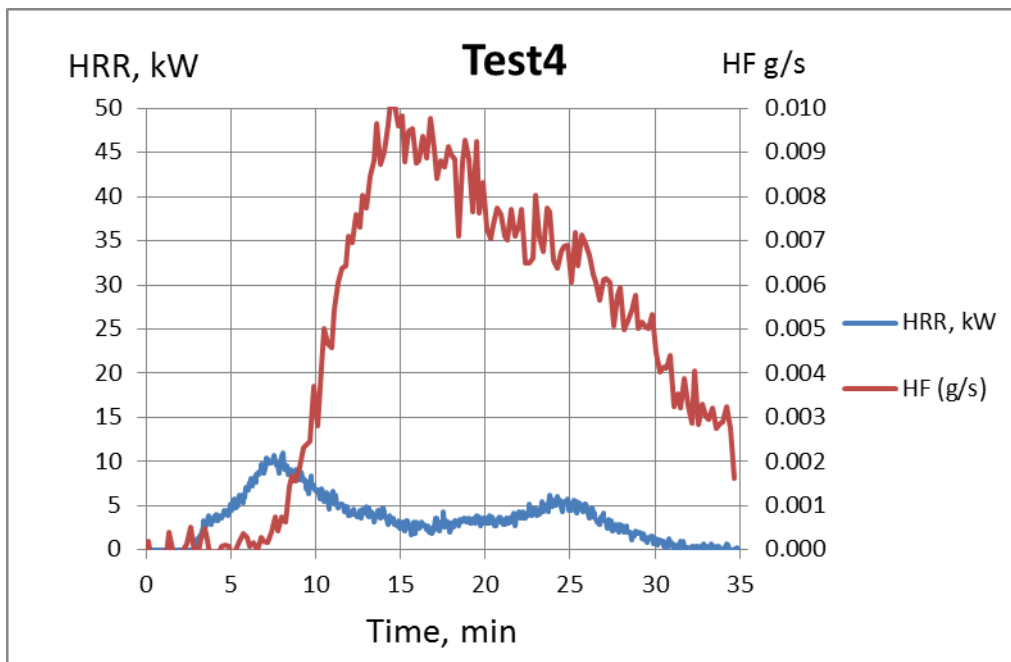

Figure 69 HRR and HF production as a function of time for test 4. The HF production only includes the readout from the FTIR so HF that is captured in the filter is not included.

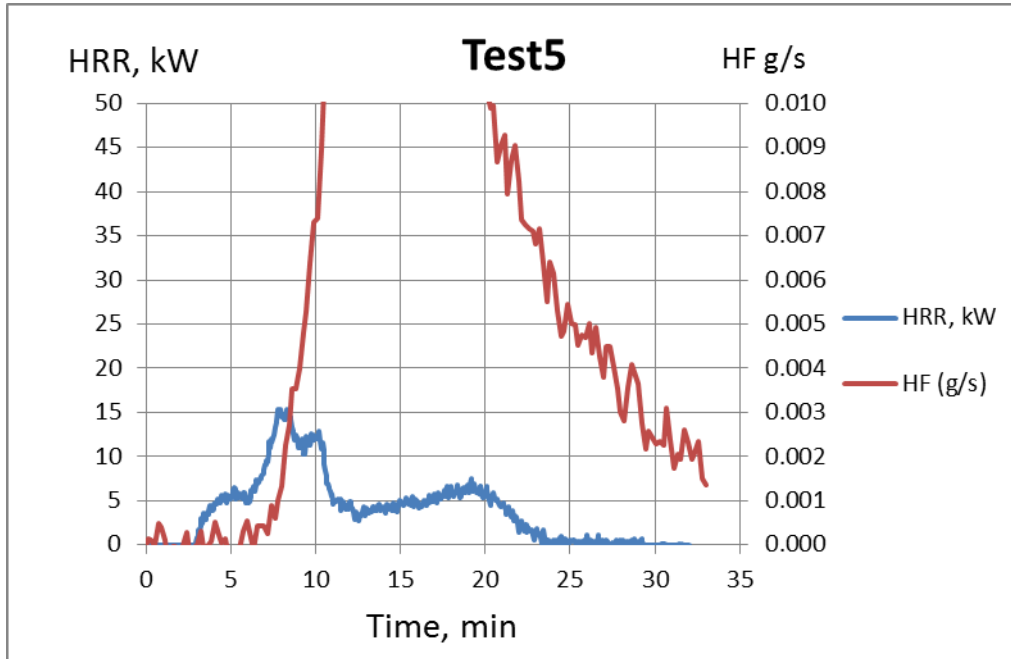

Figure 70 HRR and HF production as a function of time for test 5. The HF production only includes the readout from the FTIR so HF that is captured in the filter is not included.

The results from test 6 and 7 are available in Table 17 and Figure 70. As seen the yields of HF is much lower for the laptop cells, in fact the HF detected online was below the determined detection limit. Partly this is because the burnable mass in the laptop cells is also the plastic around the battery. But this does not explain all the difference. One plausible explanation is that the laptop cells exploded with liquid splashed on the walls in the equipment and some slat might have been missed there.

Table 17 Results of HF analysis with FTIR from test 6-7.

Test no	Max production rate (g/s)	Total amounts from FTIR (g)	Total amounts from filter (g)	Total amounts (g)	Total yields (mg/g)
6	0.0029	1.2	1.0	2.2	15
7	0.0011	Not detected	1.9	1.9	7.3

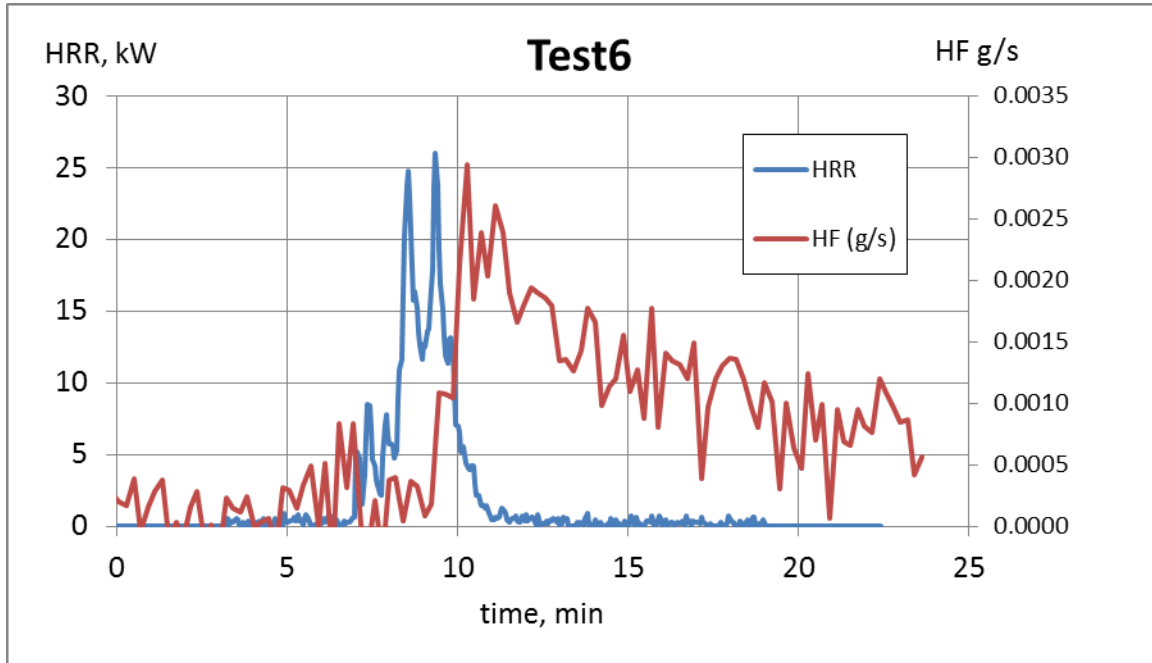

Figure 71 HRR and HF production as a function of time.

6.5 Discussion

Looking at the results from these reduced scale tests alone the emission data can be difficult to interpret. An important aspect in this context is a comparison with emission data from a traditional car fire. Emission data from a complete vehicle fire is scarce. Lönnemark and Blomqvist⁶ have made measurements both on a full scale fire and parts of a vehicle like door panels, dashboard etc. The vehicle tested in the full scale fire was a medium class model from 1998. No HF could be detected in these tests either in the small-scale tests or in the full scale test but significant amounts of HCN (NGV 1.8 ppm, TGV 3.6 ppm), HCl (TGV 5 ppm) and SO₂ (NGV 2 ppm, TGV 5ppm).

Recently Lecocq, Bertana, Truchot and Mairlair reported emission data from both a full-scale fire of a fully charged Electric Vehicle (EV) and a full-scale fire of a similar Diesel vehicle fully gassed⁷. This showed an initial peak of HF produced for both vehicles. This peak was higher than the amount of HF produced later in the fire stage when the battery started to burn in the EV but the amount of HF produced by EVs were at least twice the amount from the Diesel vehicles. The amounts reported are presented in Table 18. The initial HF peak might have been caused by the AC liquid.

The battery cells tested in this study were power optimized cells that one could find in a plug-in hybrid electric vehicle (PHEV). A typical PHEV could have 432 cells (9.7 kWh, 345.6 VDC nom, 108s4p, cell: 7Ah, 3.2 V nominal). This means that the emissions reported in the battery cell tests should be multiplied with a factor of $432/5 = 86.4$ to reflect a case where the complete battery is consumed in a fire. This results in a value of 400-1200 g HF depending on SOC with a low value for a high SOC. This is in the same order of magnitude as the valued reported by Leqocq et. al. (657 and 919 respectively) as presented in Table 18.

Similar, if the result from the burner tests are extrapolated to the amount of HF one would get if the entire amount of electrolyte in a vehicle is consumed in a fire, one ends up in a

large variation of values, 1200 – 2800 g of HF. These values are on the high end and higher than the value measured in the cell tests and larger than the values reported by Leqocq et. al. However, considering the large extrapolation done here going from a small number of completely different fire scenario the differences are not that big. In the burner test the electrolyte was introduced in a pure state and it had to go into the flame. In the vehicle test one cannot be 100% sure that all electrolyte is consumed, in addition, we do not know what kind of vehicle it was in the full vehicle test, this might differ from the assumptions on power etc. that was made in the extrapolation.

Table 18 Comparison with complete vehicle fire emissions.

Study/vehicle	HF (g)	HCN (g)	HCl (g)	SO ₂ (g)
Lönnermark/Blomqvist	No HF detected	170	1400	540
Leqocq et al. Diesel1	621	167	1990	
Leqocq et al. EV1	1540	113	2060	
Leqocq et al. Diesel2	813	178	2140	
Leqocq et al. EV2	1470	148	1930	
This study, cell tests	400-1200 depending on SOC, high SOC gives low amount of HF			
This study, burner tests	1200-2800			
This study, cakecup test	950			

The experimental results in this study could not show any significant change in the constitution of gases emitted if water is used as an extinguishing media. The battery cell experiment showed a higher concentration of HF produced during the actual spraying with water but the total amount HF was still the same. No change could be observed in the burner tests due to introduction of water.

7 Conclusions

The work presented here shows that it is possible to use FTIR to measure HF and POF_3 online in fire tests including Li-ion batteries at different scales.

POF_3 was detected in all the small scale tests using pure electrolyte. However, no POF_3 was detected in the tests on cells. The detection limit for POF_3 was 6 ppm. Extrapolating from the small scale tests to the cells tests one ends up at concentrations below 6 ppm, which probably explains why no POF_3 was detected in these tests.

It is an important finding that POF_3 is emitted from a battery fire as this will increase the toxicity of the fire effluents. The amount of POF_3 is shown to be significant, 5-40 % of the HF emissions on a weight basis.

No PF_5 could be detected in any of the tests. The reason for this is probably the high reactivity of this specie. This was also demonstrated by the difficulty to produce a calibration gas mixture for PF_5 .

There was no apparent experimental evidence that using water had a significant impact on the amount of HF produced if water is used as an extinguishing media. The use of water to extinguish a battery fire has the potential to shift the chemistry to favour the production of HF over POF_3 . The toxicity of POF_3 is not known but substances similar to POF_3 are highly toxic, more toxic than HF. Therefore shifting the chemistry to favour the production of HF over POF_3 may be toxicologically favourable. More information is needed to resolve this issue especially as POF_3 can be emitted under other cell venting situations and not only fires.

Extrapolating the results from these experiments one ends up in the same order of magnitude in amount of HF as reported in the few available complete EV vehicle burns. This is an indication that the small scale experiments conducted in this project provide useful information to analysing the risks associated with emissions from Li-ion batteries in fires and the impact of water application during the fire.

8 References

- ¹ Hygiensiska gränsvärden AFS 2011:1, 8 Hygieniska gränsvärden, AFS 2011:18 Hygieniska gränsvärden Arbetsmiljöverkets föreskrifter och allmänna råd om hygieniska gränsvärden, ISBN 78-9 91-7 7930-5 559-8 ISSN 650-3163 ARBETSMILJÖVERKET 112 79 Stockholm
- ² Yang, H., Zhuang, G. V. and Ross, P. N. Jr, "Thermal Stability of LiPF₆ salt and Li-ion battery electrolytes containing LiPF₆, Journal of Power sources 161 (2006) 573-579
- ³ Xiang-Guo Teng, Fa-Qiang Li, Pei-Hua Ma, Qi-Du Ren and Shi-You Li "Study on thermal decomposition of lithium hexafluorophosphate by TG-FT-IR coupling method". *Thermochimica Acta*, 2005, 436, 30-34
- ⁴ Kirk-Othmer Encyclopedia of Chemical Technology, John Wiley & Sons, 1994, Vol. 11.
- ⁵ ISO 19702:2006, Toxicity testing of fire effluents -- Guidance for analysis of gases and vapours in fire effluents using FTIR gas analysis
- ⁶ Lönnermark AN, Blomqvist, P., Emissions from an automobile fire, *Chemosphere* 62, 1043-1056, 2006.
- ⁷ Lecocq, A., Bertana, M., Truchot, B., Marlair, G., "Comaprison of the Fire Consequences of an Electric Vehicle and an Internal Combusion Engine Vehicle", FIVE 2012, September 27-28 2012 Chicago USA

Appendix A Tests conducted in burner

Tests conducted are listed in Table 1. Each of the tests are then presented in tables (test procedure) and figures.

Table 1 Tests conducted

Test nr	Type of test	Fuel	Comment
1	burner	Propane only	Initial test to determine propane HRR
2	Burner + needle	Propane and 5.9 ml/min DME	DME works not as spray but as a beam, possibility that all DME not burnt
3	Burner + Needle	Propane and 5.9 ml/min DME	Needle in bottom of burner instead of top
4	Burner + Needle	Propane and 5.9 ml/min DME	Needle inserted outside of burner
5	Burner + spoon	Propane and 2.4 ml/min DMC	Not a very successful attempt
6	Burner + Needle	Propane and 12 ml/min DMC	and later 5 ml/min
7	Burner + Needle	Propane and 20 ml/min DMC	Interrupted as holder melted
8	Burner + Needle	Propane and 20-18 ml/min DMC	Burner placed a bit lower under the collecting hood
9	Burner + Needle	Propane and DMC 18 ml/min	
10	Burner + Needle	Propane and DMC 18 ml/min with 1 M salt	
11	Burner + needle	Propane and DME 18 ml/min	
12	Burner + needle	Propane and DME 18 ml/min with 0.4 M salt	
13	Burner + Needle	Propane and DMC 18 ml/min 1 M salt	
14	Burner + Spoon	Propane and DMC 1.8 ml/min	
15	Burner + spoon	Propane and DMC 1.8 ml/min + 1M salt	
16	Burner + spoon	Propane and DME 1.8 ml/min + 0.4 M salt	
17	cakecup	DMC + salt 1:1	No external heating, did not burn very well
18	cakecup	DME + salt 1:1	No external heating, did not burn very well

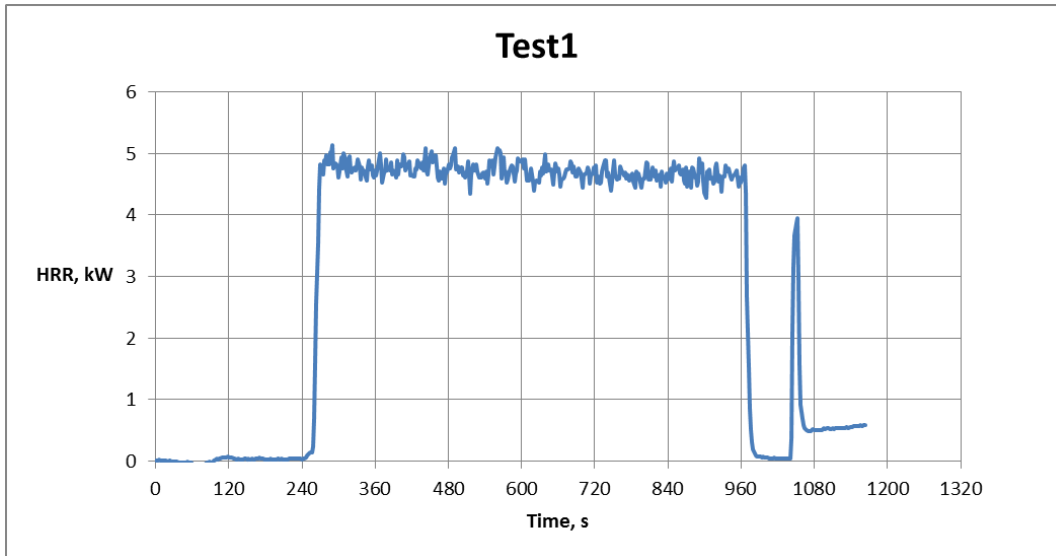

Figure 1 HRR from test 1, propane burner at 7 sp.

Table 2 Test procedure test 2

Time Min:sec	Comment
0	FTIR and HRR measurement started
1:00	Burner with 7 sp propane started
1:34	First numbers from FTIR available
6:00	Start DME injection 5.9 ml/min, DME works not as spray but as a beam, possibility that all DME not burnt

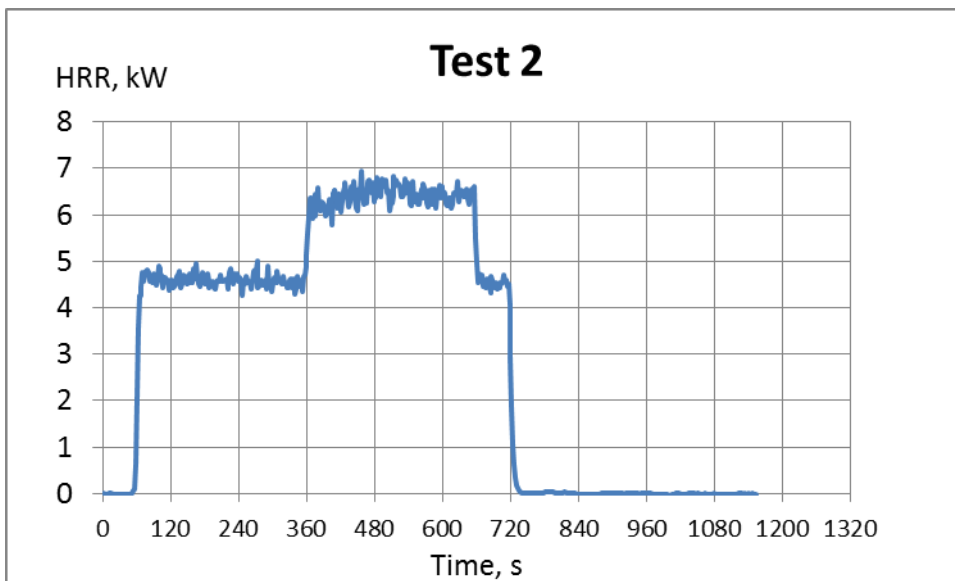

Figure 2 HRR from test 2

Table 3 Test procedure test 3

Time Min:sec	Comment
0	FTIR and HRR measurements started
1:00	Burner with 7 sp propane started
1:30	First numbers from FTIR available
6:00	Start DME injection 5.9 ml/min, Needle inserted in bottom of burner instead
8:00	test was interrupted as the spray hit the burner

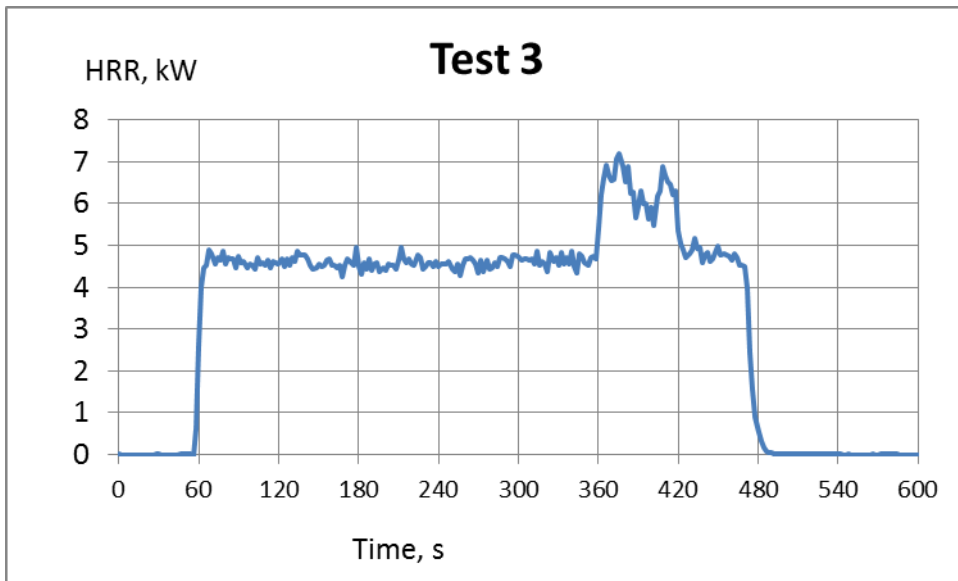

Figure 3 HRR from test 3

Table 4 Test procedure test 4

Time Min:sec	Comment
0	FTIR and HRR measurement started
1:00	Burner with 7 sp propane started
1:33	First numbers from FTIR available
4:00	Start DME injection 5.9 ml/min, Needle placed outside of burner

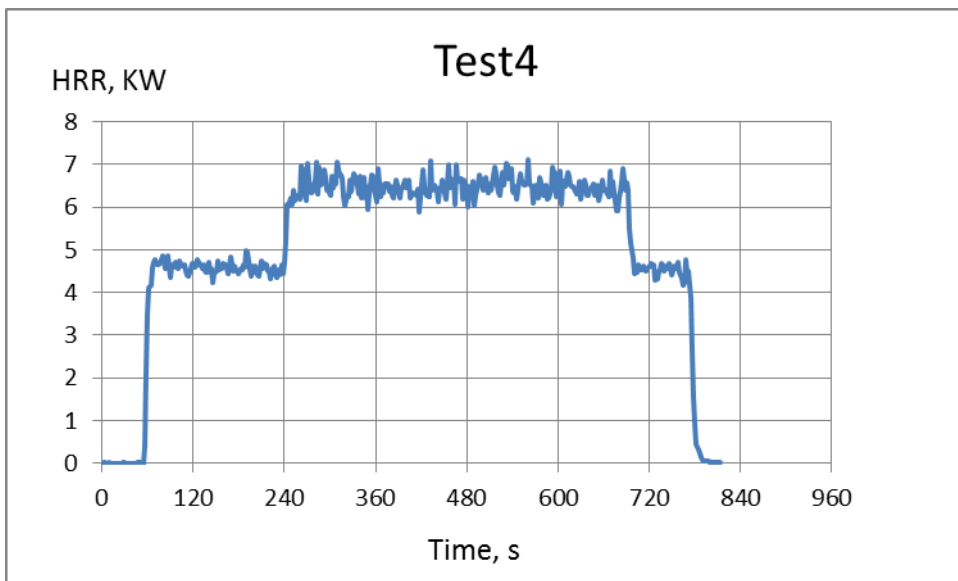

Figure 4 HRR from test 4

Table 5 Test procedure test 5

Time Min:sec	Comment
0	FTIR and HRR measurement started
1:03	First numbers from FTIR available
2:00	Burner start
10:30	Start DMC injection 2.4 ml/min onto spoon placed in flame
	Not a successful attempt

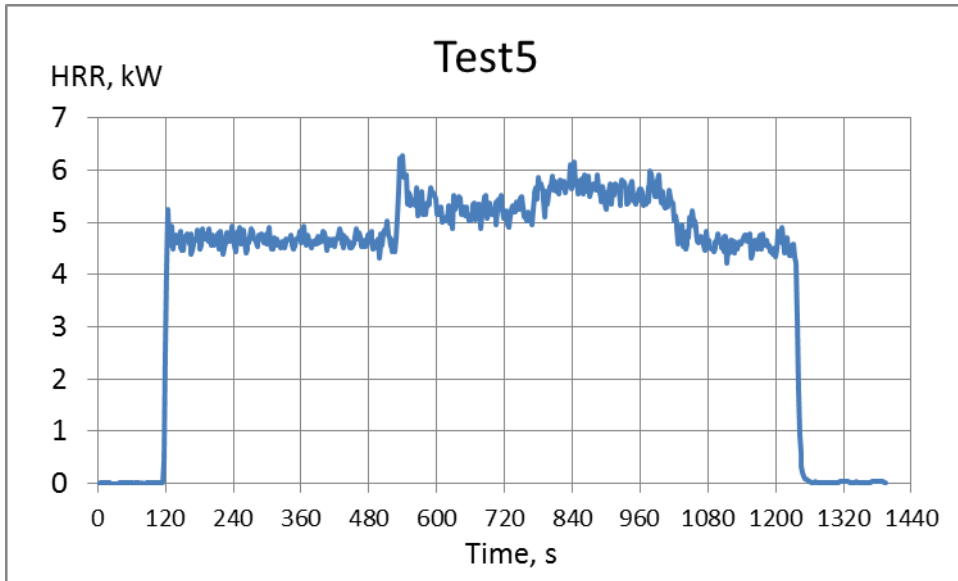

Figure 5 HRR from test 5

Table 6 Test procedure test 6

Time Min:sec	Comment
0	FTIR and HRR measurement started
1:00	Burner (propane) start
1:23	First numbers from FTIR available
6:00	Start injecting DMC 12 ml/min onto spoon
6:45	Injection interrupted
7:30	Injection started again flow 5 ml/min
8:00	Injection interrupted
8:57	Flame extinguished
10:09	Flame lit again
10:30	Injection 5 ml/min
12:00	Injection ended and flame turned off

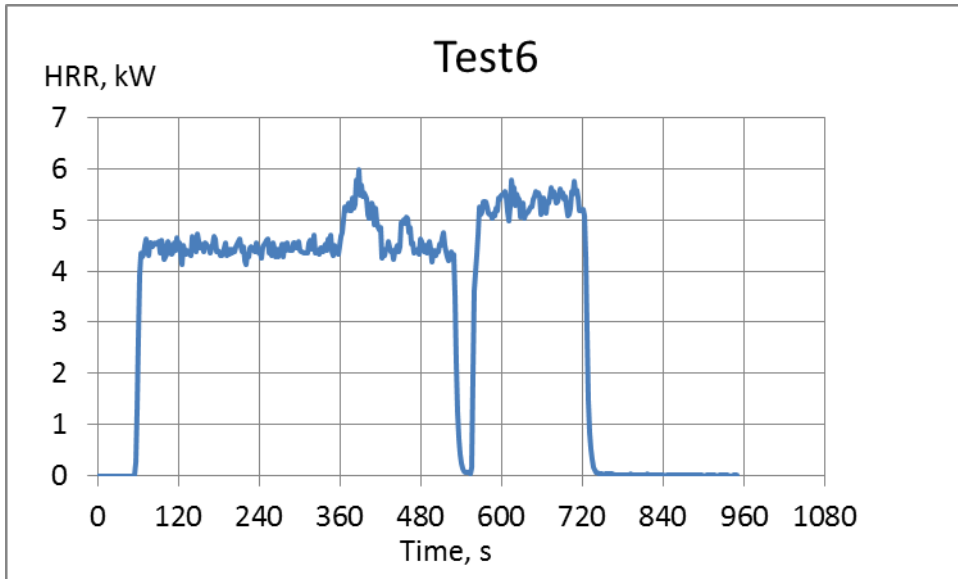

Figure 6 HRR from test 6

Table 7 Test procedure test 7

Time Min:sec	Comment
0	FTIR and HRR measurement started
0:41	First numbers from FTIR available
1:10	Burner start
6:00	Start injecting DMC 20 ml/min spray
7:45	Injection interrupted as holder melted
10:00	Burner off

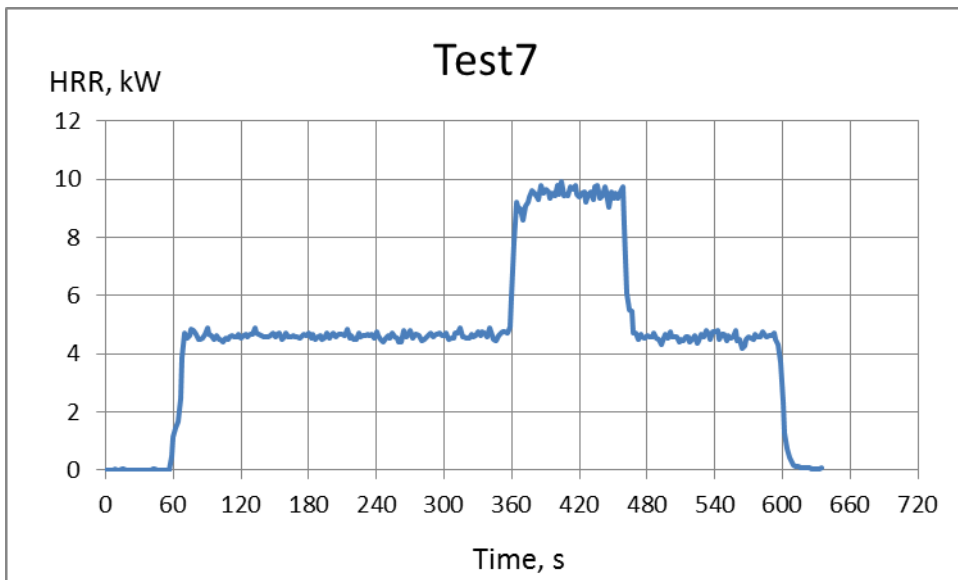

Figure 7 HRR from test 7

Table 8 Test procedure test 8

Time Min:sec	Comment
0	FTIR and HRR measurement started
0:44	First numbers from FTIR available
1:00	Burner start, burner placed lower in relation to collecting hood
6:00	Start injecting DMC 20 ml/min spray
8:30	Start decreasing injection until 18 ml/min
9:30	Injection off

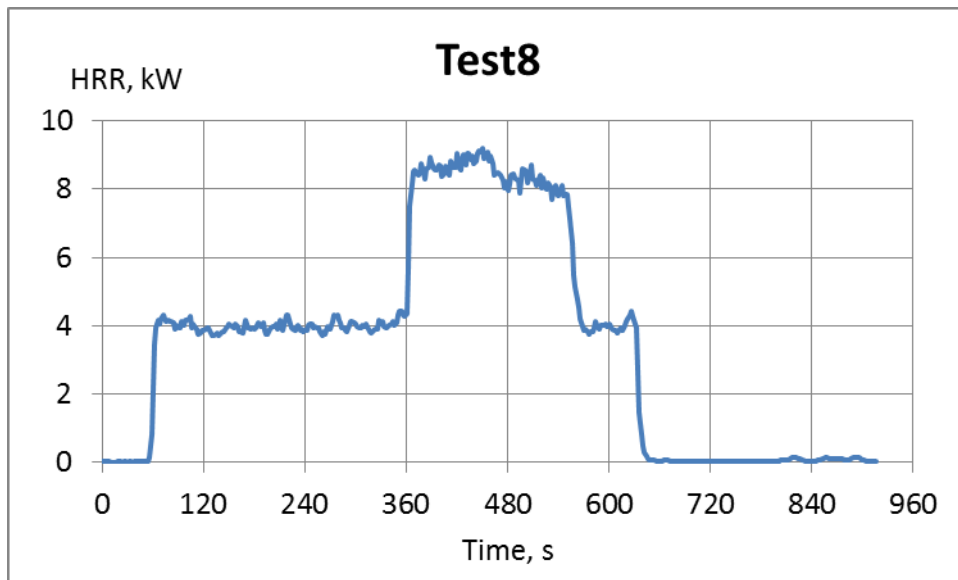

Figure 8 HRR from test 8

Table 9 Test procedure test 9

Time Min:sec	Comment
0	FTIR and HRR measurement started
0:33	First numbers from FTIR available
1:00	Burner start
4:00	Start injecting DMC 18 ml/min spray
7:00	DMC off
10:30	Burner off

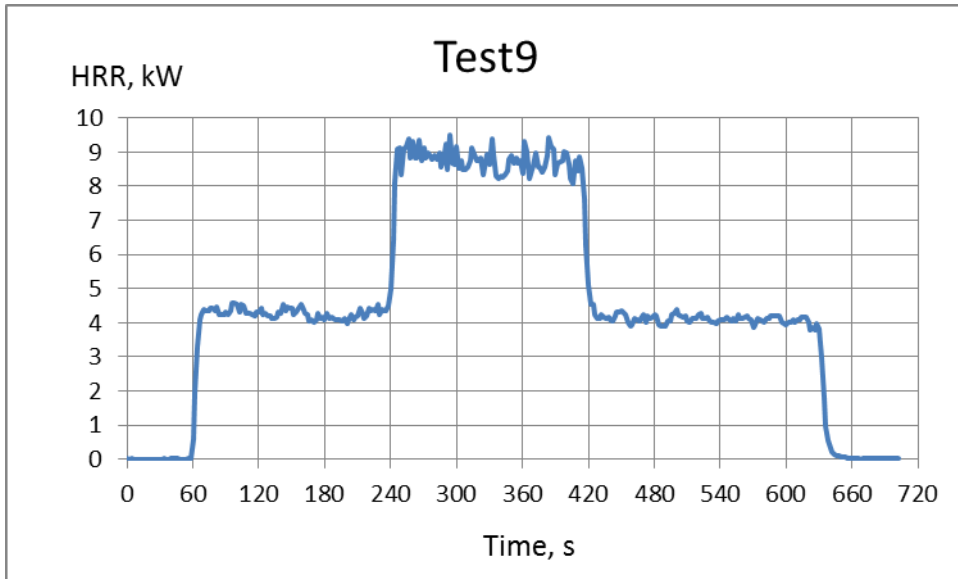

Figure 9 HRR from test 9

Table 10 Test procedure test 10

Time Min:sec	Comment
0	FTIR and HRR measurement started
0:54	First numbers from FTIR available
1:09	Burner start
4:00	Start injecting DMC + salt 18 ml/min spray
6:00	DMC off
12:20	Burner off

Table 11 Test Procedure test 11

Time Min:sec	Comment
0	FTIR and HRR measurement started
0:59	First numbers from FTIR available
1:00	Flame start
4:00	Start injecting DME 18 ml/min, flame turns purple, salt still available in system!
8:40	Stop spray
13:55	Start injecting DME again after cleaning of hoses
15:30	Stop injection
16:43	Burner off

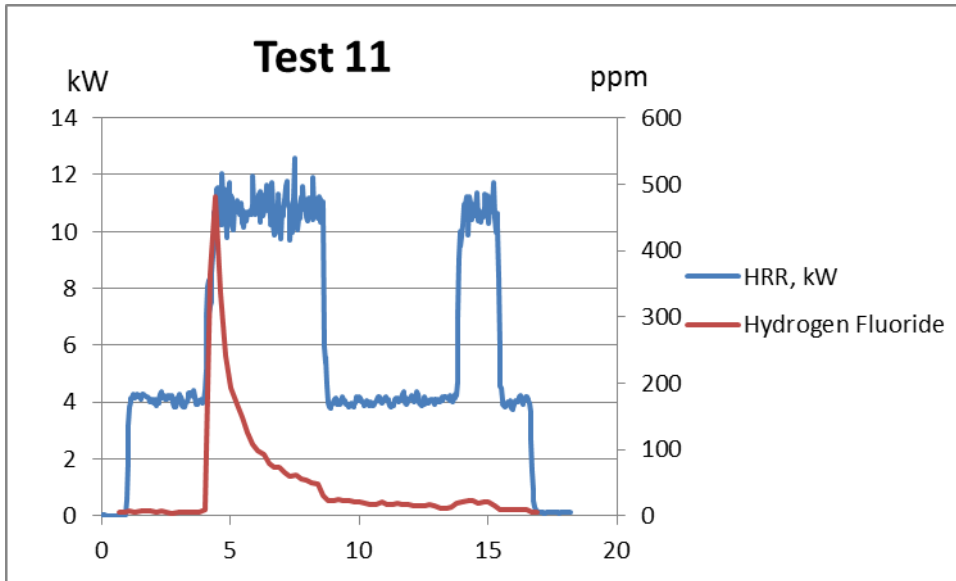

Figure 10 HRR and HF concentration test 11

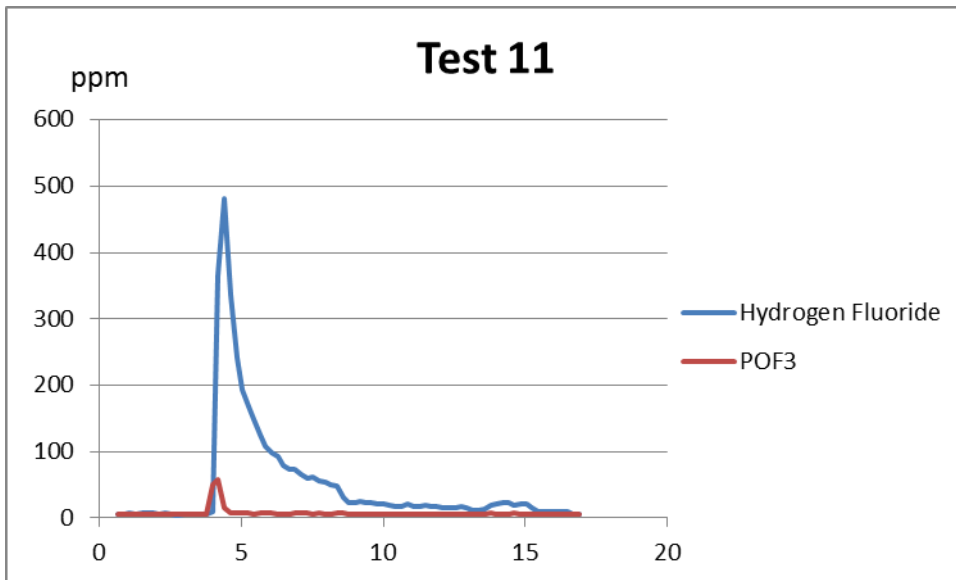

Figure 11 HF and POF_3 concentration test 11

Table 12 Test procedure test 12

Time Min:sec	Comment
0	FTIR and HRR measurement started
0:30	Flame start
0:43	First numbers from FTIR available
2:30	Start injecting DME 18 ml/min + 0.4 M salt
5:00	Stop spray
10:00	Burner off

Table 13 Test procedure test 13

Time Min:sec	Comment
0	FTIR and HRR measurement started
0:30	Flame start
0:45	First numbers from FTIR available
2:30	Start injecting DMC + 1 M salt 18 ml/min
3:20	Flow increased to 20 ml/min
4:00	Stop spray due to no spray
5:40	Injection clean DMC
7:00	Gets spray
8:00	Start salt + DMC injection
11:00	Injection end
16:22	Burner off

Table 14 Test procedure test 14

Time Min:sec	Comment
0	FTIR including numbers on screen
3:00	HRR measurement started
3:30	Flame start
5:30	Start injecting DMC + 1 M salt 1.8 ml/min in spoon
7:15	Interrupted due to stop in needle

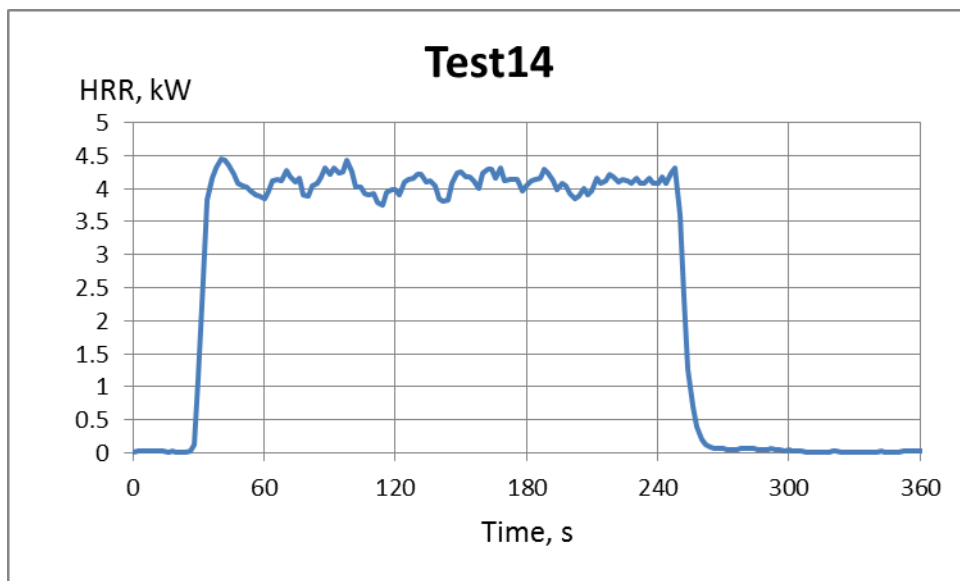
**Figure 12** HRR test 14**Table 15** Test procedure test 15

Time Min:sec	Comment
0	FTIR and HRR measurement started
0:48	First numbers from FTIR available
1:05	Flame start
3:00	Start injecting DMC 1.8 ml/min onto spoon
5:00	Start injecting DMC + salt 1.8 ml/min onto spoon
10:00	Start injecting DMC 1.8 ml/min onto spoon
11:00	Injecting water instead, come through white plug in opening
15:15	Stop injection
17:15	Burner off

Table 16 Test procedure test 16

Time Min:sec	Comment
0	FTIR and HRR measurement started
0:45	First numbers from FTIR available
1:07	Flame start
3:00	Start injecting DMC 1.8 ml/min onto spoon
5:05	Start injecting DMC + salt 1.8 ml/min onto spoon
11:15	Start injecting DMC 1.8 ml/min onto spoon
13:00	Injecting water instead
16:50	Stop injection
	Burner off

Table 17 Test procedure test 17

Time Min:sec	Comment
0	FTIR and HRR measurement started
0:47	First numbers from FTIR available
2:30	Light the 2g DMC + 2 g salt in open cup
3:40	Fire extinguishes itself
5:27	Light the 2g DMC + 2 g salt in open cup
6:40	Fire extinguishes itself
10:00	end

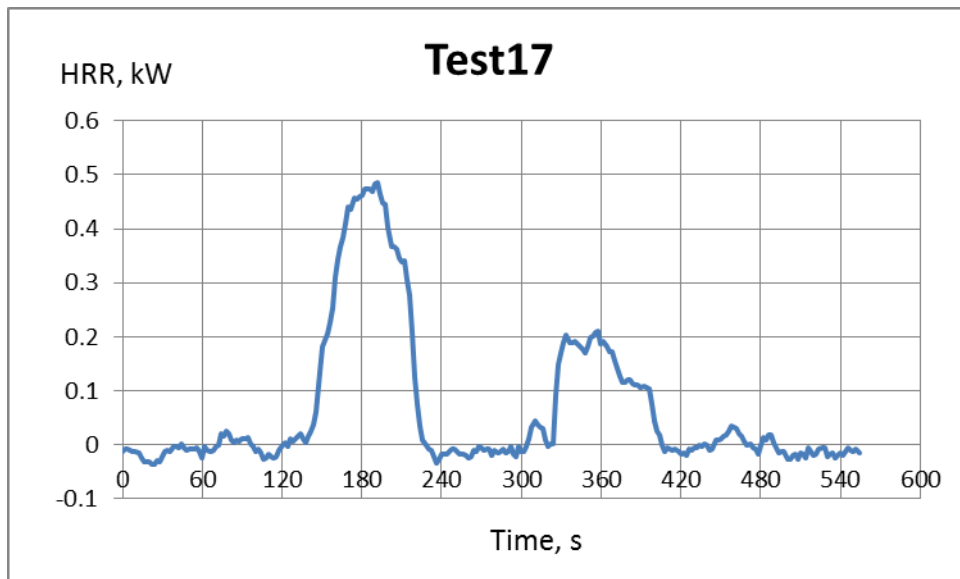
**Figure 13** HRR test 17**Table 18** Test procedure test 18

Time Min:sec	Comment
0	FTIR and HRR measurement started
0:62	First numbers from FTIR available
6:50	Light the 2g DMC + 2 g salt in open cup
7:30	Fire extinguishes itself
10:48	Light the 2g DMC + 2 g salt in open cup
11:50	Fire extinguishes itself
10:00	end

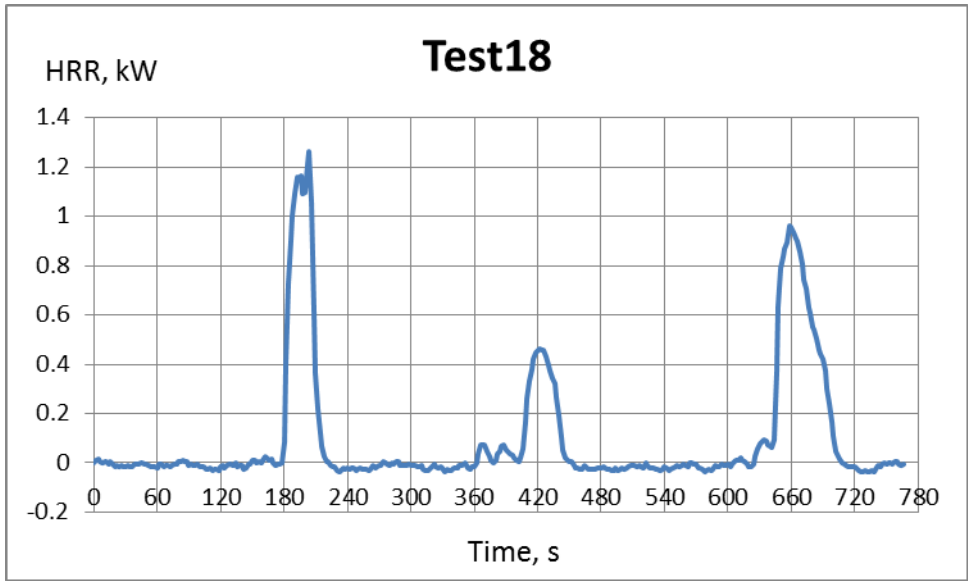

Figure 14 HRR from test 18

No test 19 was conducted

Table 19 Test procedure test 20

Time Min:sec	Comment
0	HRR measurement started
1:30	FTIR measurements start
1:59	FTIR values available
2:30	Start propane 7 skd
7:30	Stop propane

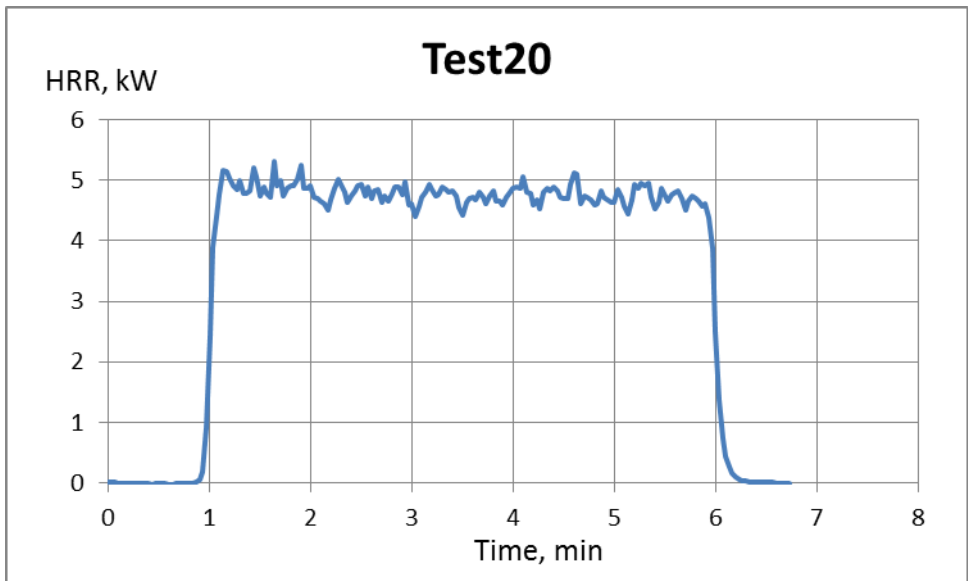
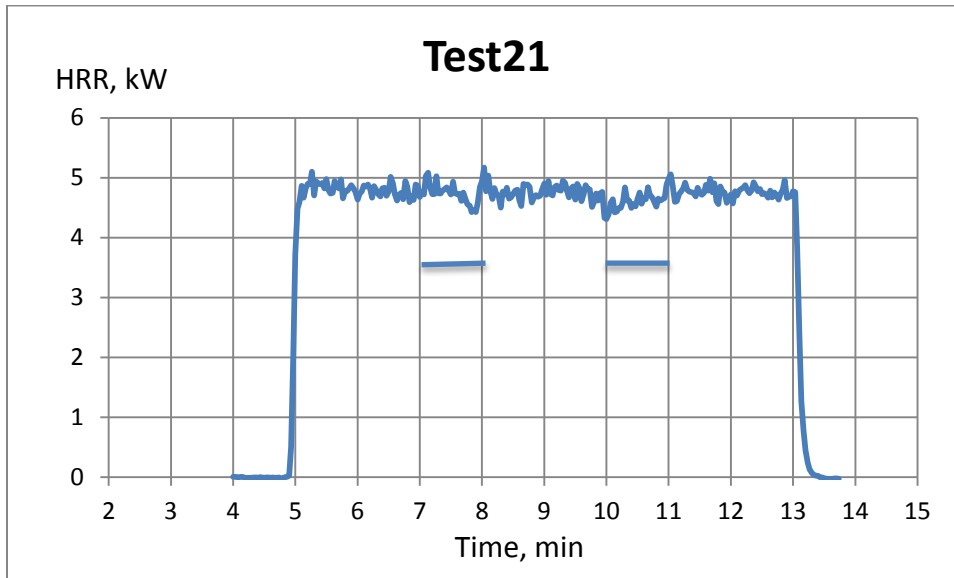

Figure 15 HRR from test 20 Propane only gave a mean HRR of 4.78 kW

Table 20 Test procedure test 21

Time Min:sec	Comment
0	FTIR measurement started
0:28	FTIR values available
4:00	Start HRR measurements
5:00	Flame start
7:00-8:00	Spray water into flame
10:00-11:00	Spray water into flame
13:00	Stop flame

**Figure 16** HRR from test 21. Propane + water injection by spraybottle. Sprayinjection of water marked in figure with horizontal lines**Table 21** Test procedure test 22

Time Min:sec	Comment
0	FTIR measurement started
0:25	First numbers from FTIR available
2:00	Start HRR measurements
3:00	Start propane flame
5:00	Start injecting DMC 15 ml/min
7:00	Start injecting DMC with salt 1 M
9:00	DMC only, spray not OK until 9:40
13:00	Injecting ethanol
19:00	Stop flame, inject water through needle

Table 22 Test procedure test 23

Time Min:sec	Comment
0	FTIR measurement started
0:40	First numbers from FTIR available
2:00	Start HRR measurements
3:00	Start propane flame
5:00	Start injecting DMC 15 ml/min
7:00	Start injecting DMC with salt 0.4 M
10:00	Propane decreased to 5 skd
11:30	Pump stopped
12:00	Injecting ethanol
20:00	Injecting DMC and salt 0.4 M
23:00	Injecting DMC only
25:00	Injecting ethanol only
27:00	Injecting water only
30:00	Propane only
33:00	Stop flame

Table 23 Test procedure test 24

Time Min:sec	Comment
0	FTIR measurement started
0:27	First numbers from FTIR available
2:00	Start HRR measurements
3:00	Start propane flame
6:00	Start injecting DMC 15 ml/min with salt problematic
11:15	Decreased to 10 ml/min
14:25	DMC finished
15:00	Start again
15:05	Started injecting weater also, stop in system directly
17:00	Stop flame

Table 24 Test procedure test 25

Time Min:sec	Comment
0	FTIR measurement started
0:37	First numbers from FTIR available
2:00	Start HRR measurements
3:00	Start propane flame 7 skd
5:00	Start injecting DMC 15 ml/min
7:00	Start injecting DMC with salt 1 M
10:00	Spary became beam, turned injection off
12:00	Stop flame

Table 25 Test procedure test 26

Time Min:sec	Comment
0	FTIR measurement started
0:38	First numbers from FTIR available
2:00	Start HRR measurements
3:00	Start propane flame 7 skd
4:00	Start injecting DMC 15 ml/min with salt 1 M
5:00	Water spray into flame
5:40	Spray became beam
7:00	Injecting water through needle for cleaning
11:00	Start injecting DMC 15 ml/min with salt 1 M
11:50	Water spray into flame
12:30	Spray became beam
15:00	Stop flame

Table 26 Test procedure test 27

Time Min:sec	Comment
0	FTIR measurement started
0:30	First numbers from FTIR available
2:00	Start HRR measurements
2:30	Cakecup with 1 M DMC placed into Cone calorimeter
2:47	Radiation starts, immediate ignition
5:45	Flames extinguish themselves
11:45	End heat exposure

Test28

0.4M salt in DME in cakecup, 15 kW/m² radiation applied as heating, spark placed above surface
Ignition about 13 s after heat radiation started.

The electrolyte burned up and then new was added at 7 minutes 35 s.

Unfortunately the FTIR program ceased to work during this test.

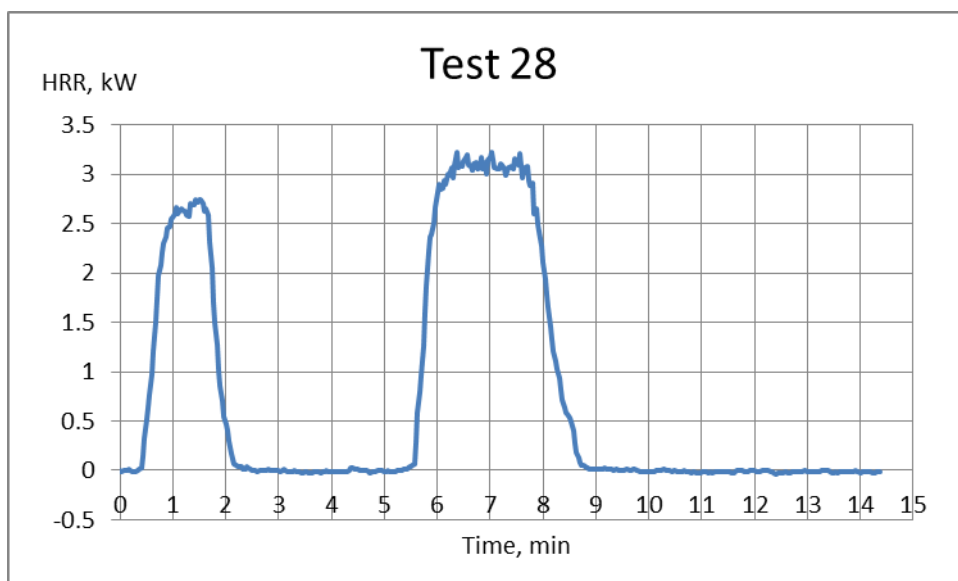
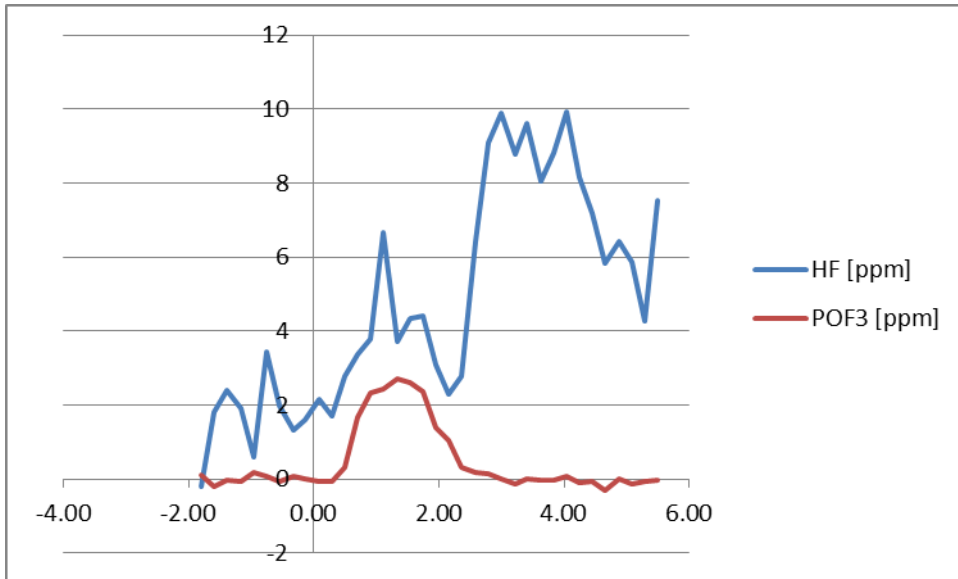
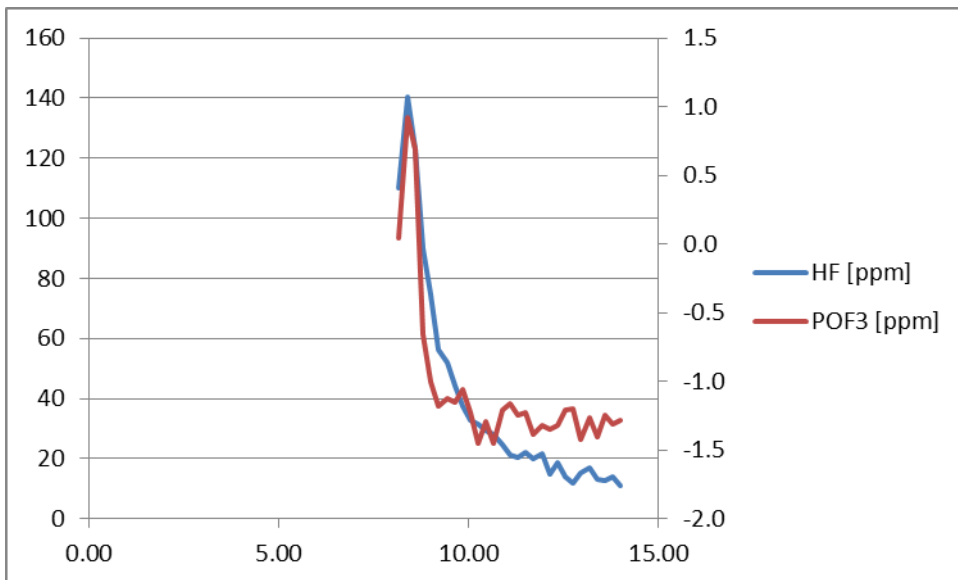

Figure 17 HRR test 28

Figure 18 HF and POF₃ test 28Figure 19 HF and POF₃ test 28

Appendix B Results from battery cell tests

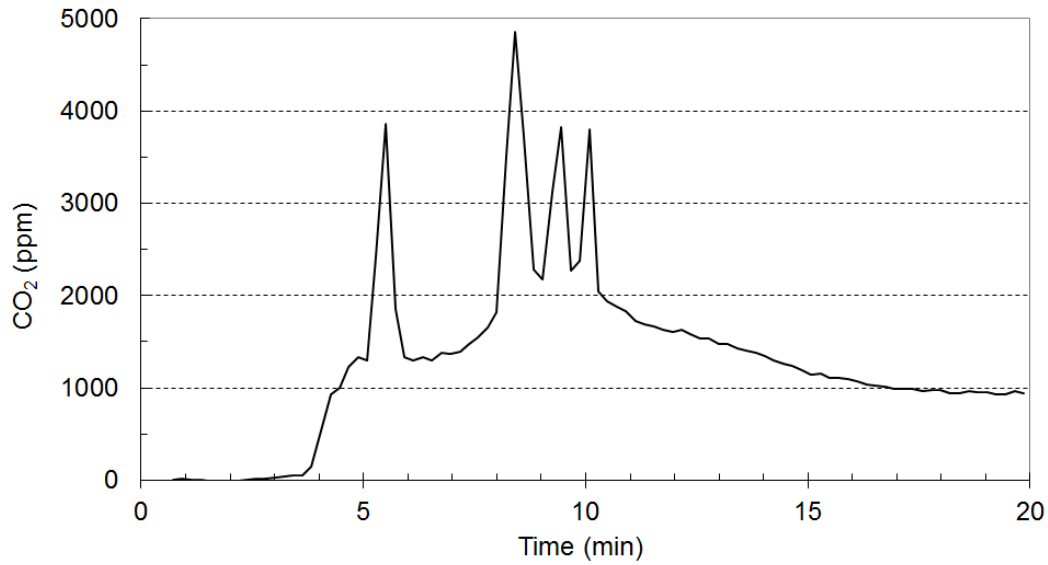

Figure 1 Concentration of CO₂ measured by FTIR in Test 1.

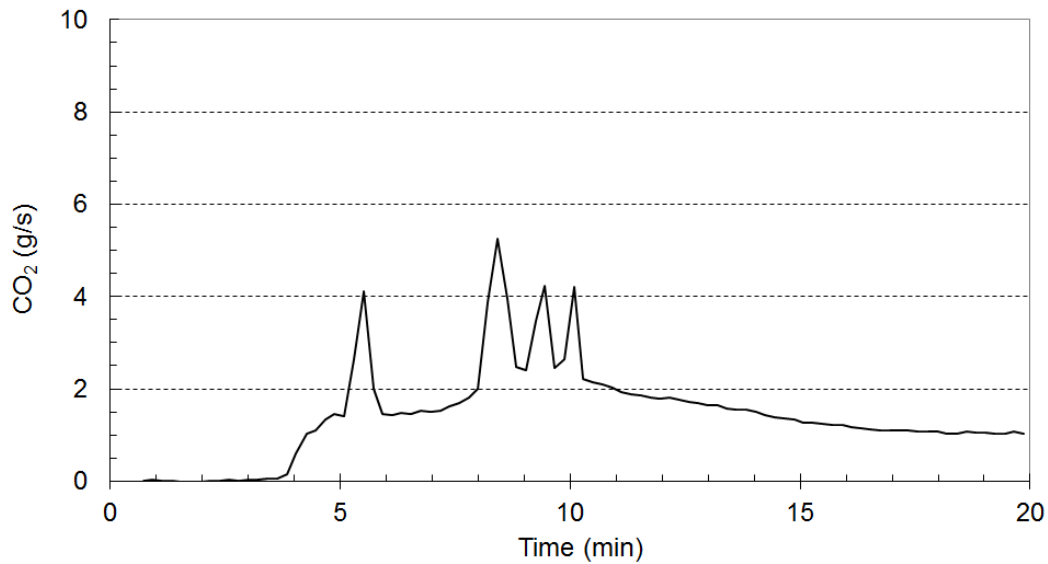

Figure 2 Production rate of CO₂ measured by FTIR in Test 1.

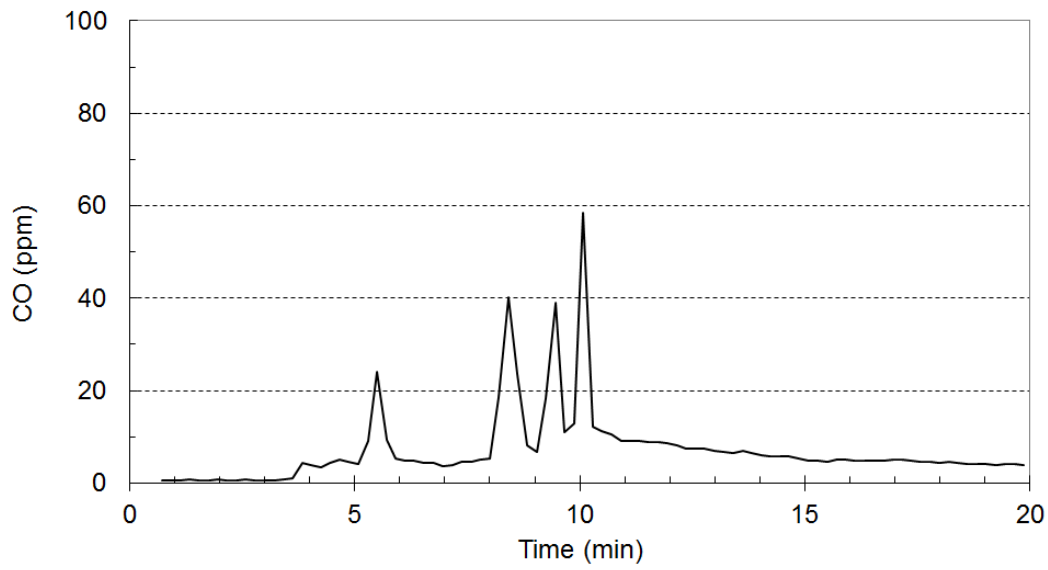

Figure 3 Concentration of CO measured by FTIR in Test 1.

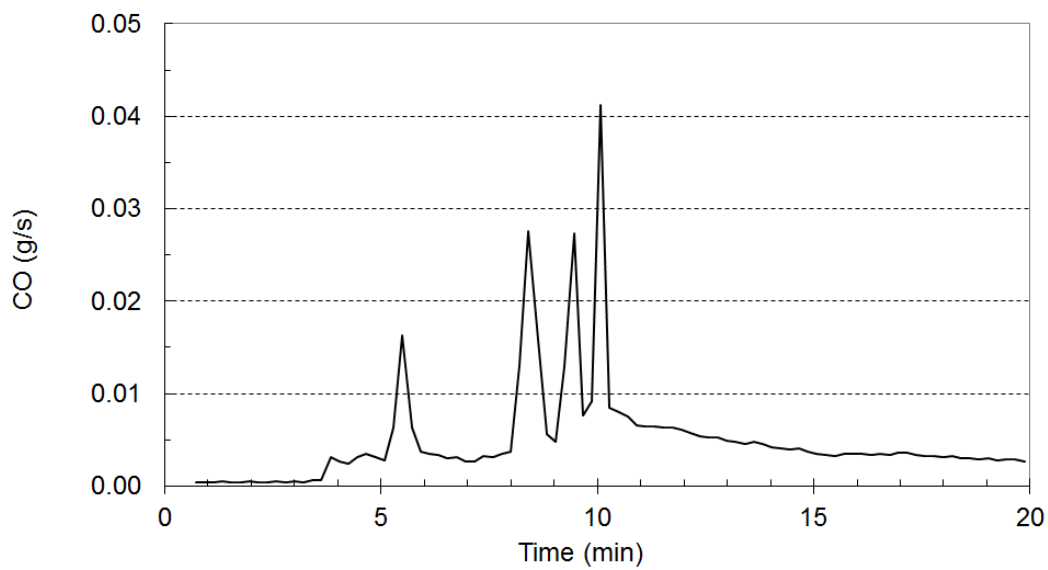

Figure 4 Production rate of CO measured by FTIR in Test 1.

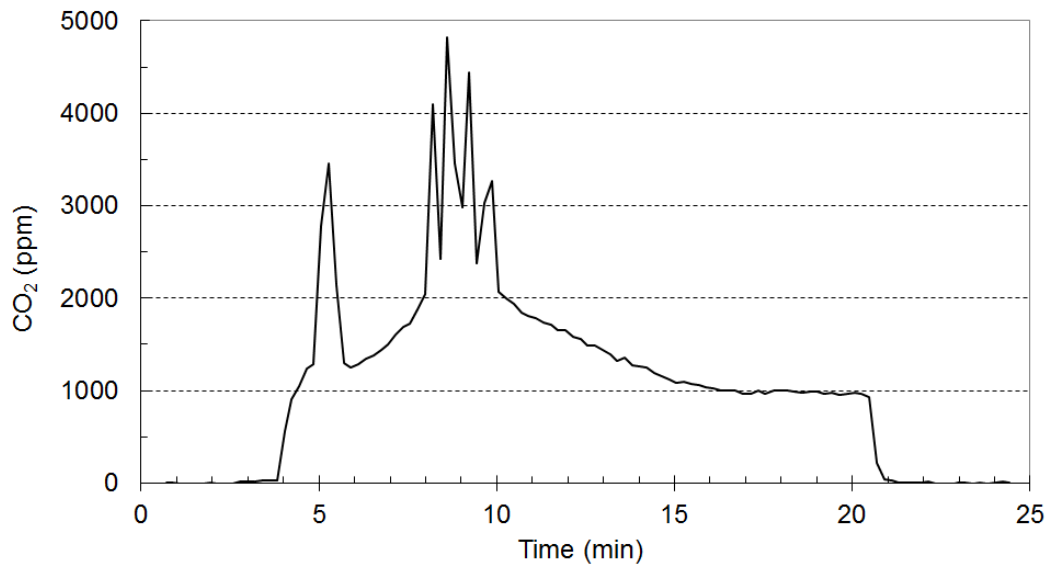

Figure 5 Concentration of CO₂ measured by FTIR in Test 2.

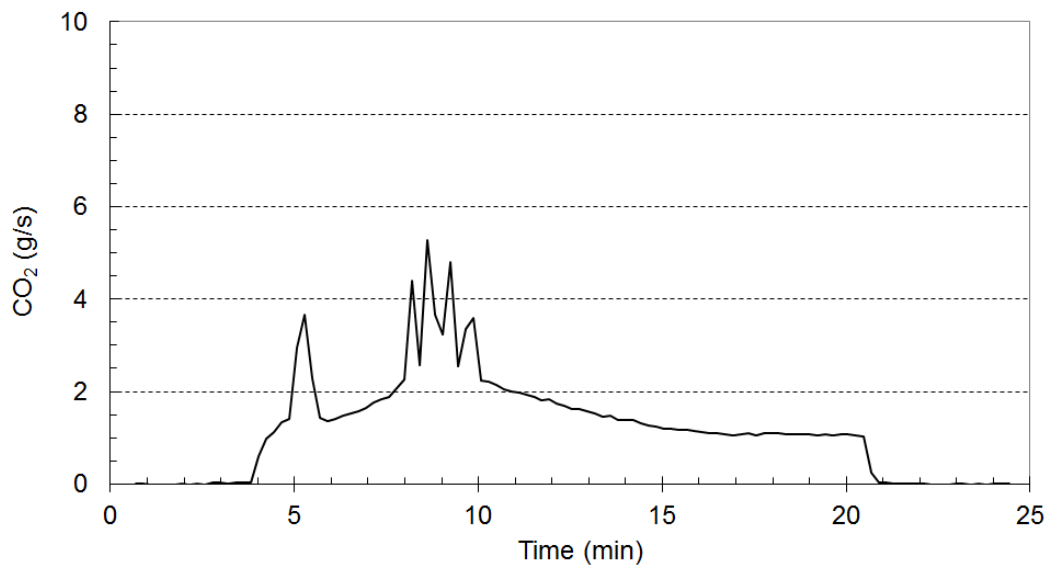

Figure 6 Production rate of CO₂ measured by FTIR in Test 2.

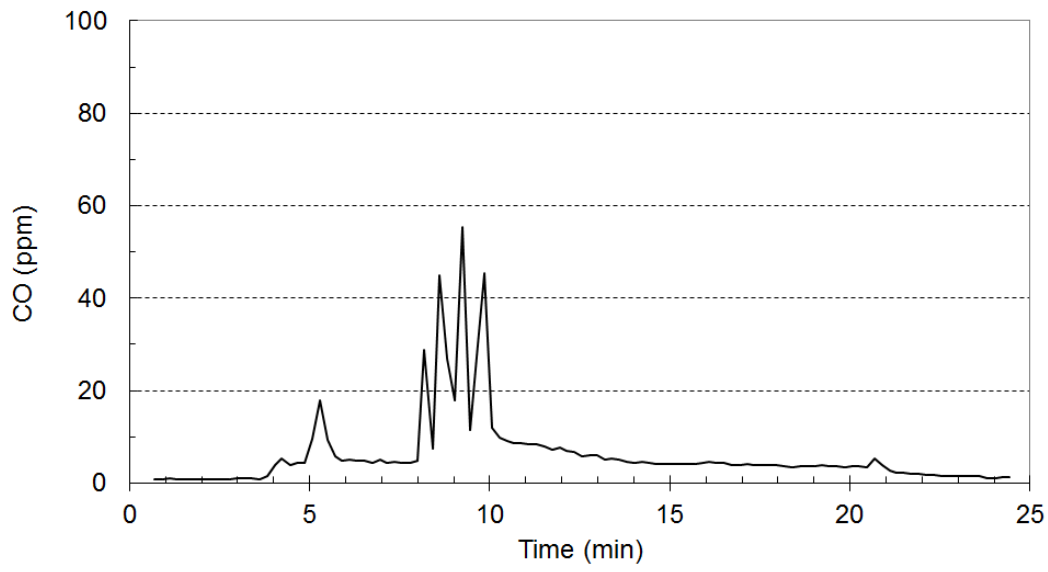

Figure 7 Concentration of CO measured by FTIR in Test 2.

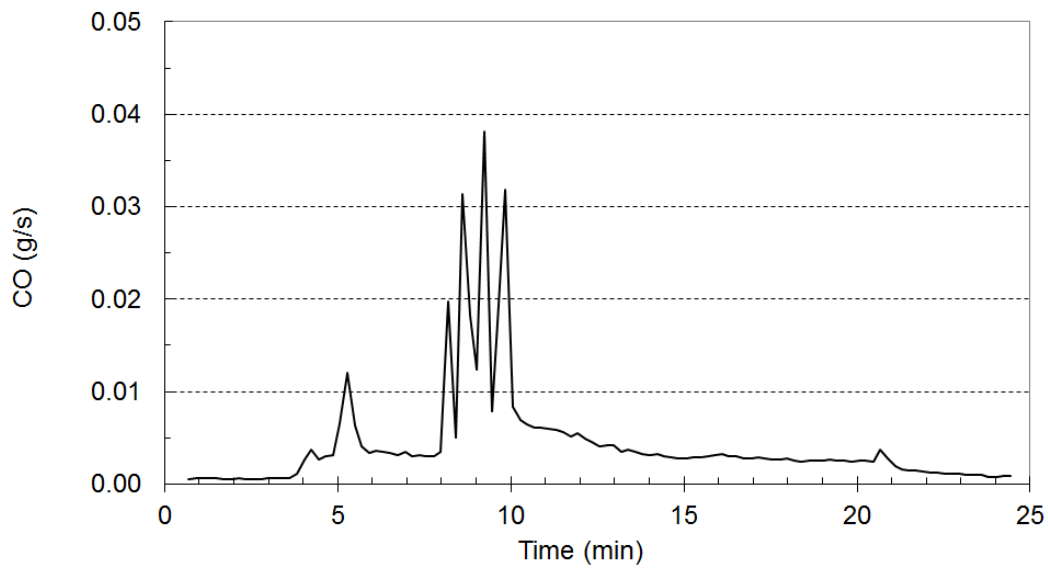

Figure 8 Production rate of CO measured by FTIR in Test 2.

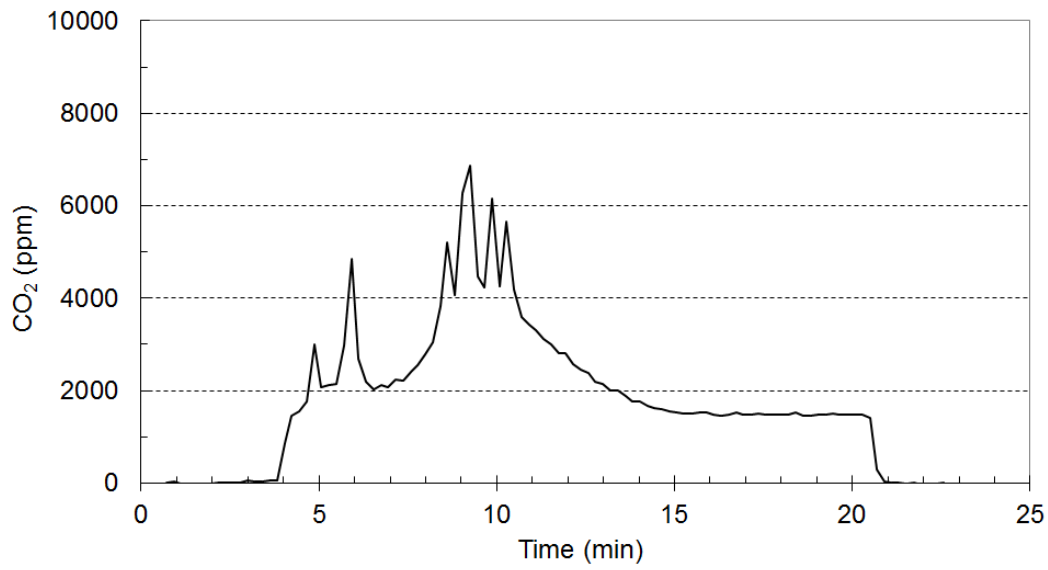

Figure 9 Concentration of CO₂ measured by FTIR in Test 3.

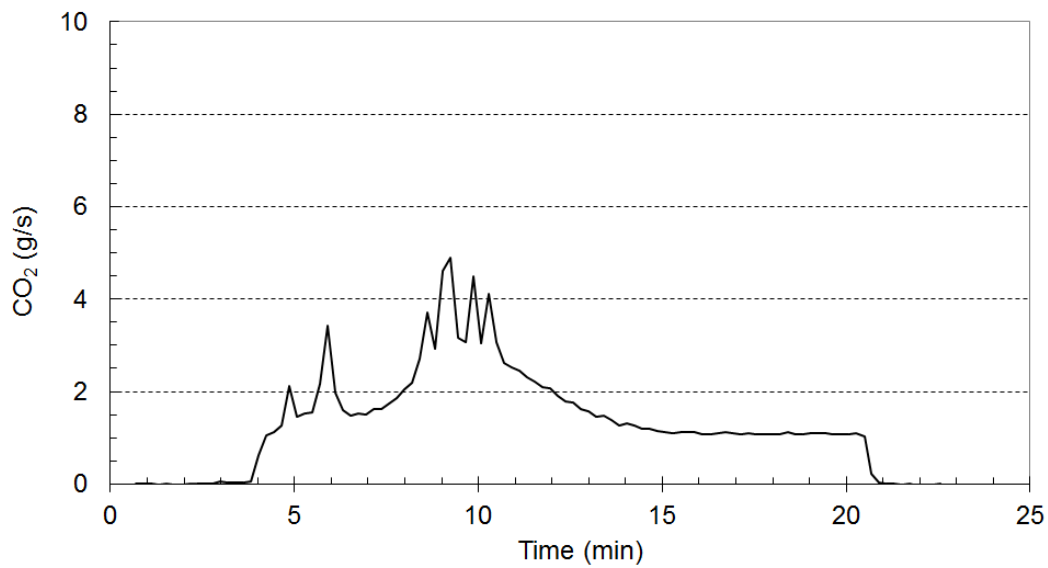

Figure 10 Production rate of CO₂ measured by FTIR in Test 3.

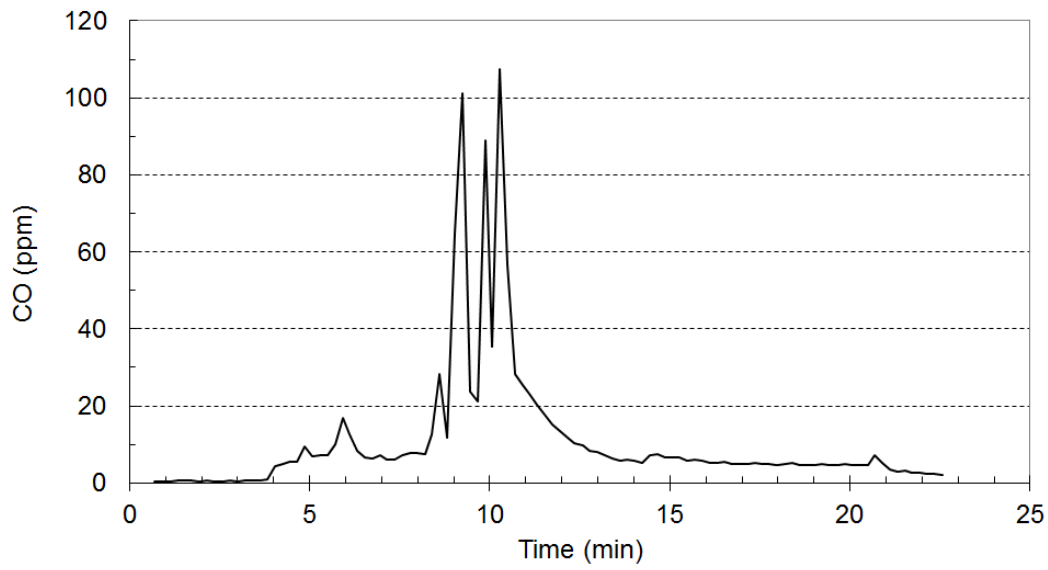

Figure 11 Concentration of CO measured by FTIR in Test 3.

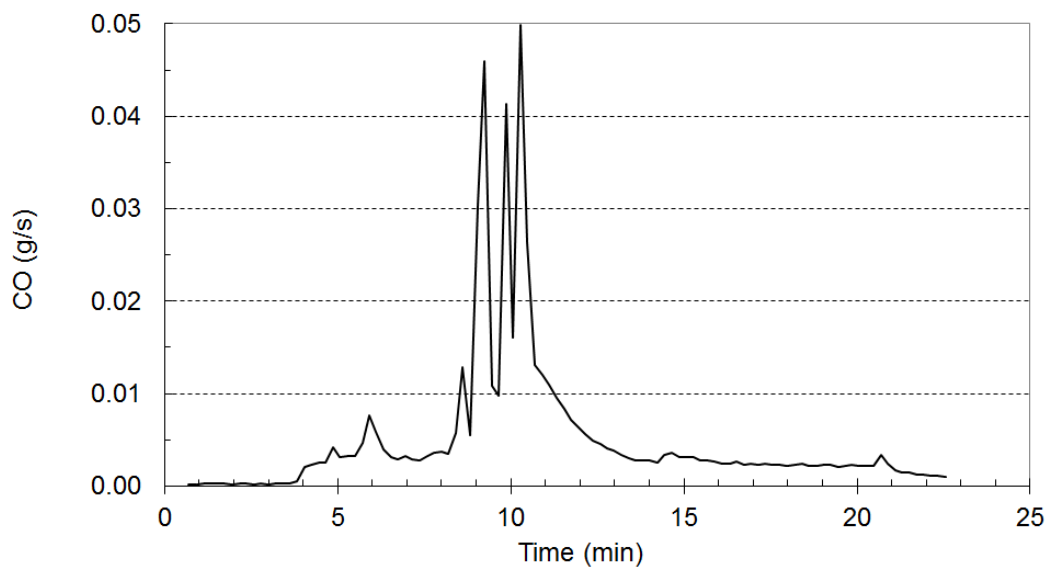

Figure 12 Production rate of CO measured by FTIR in Test 3.

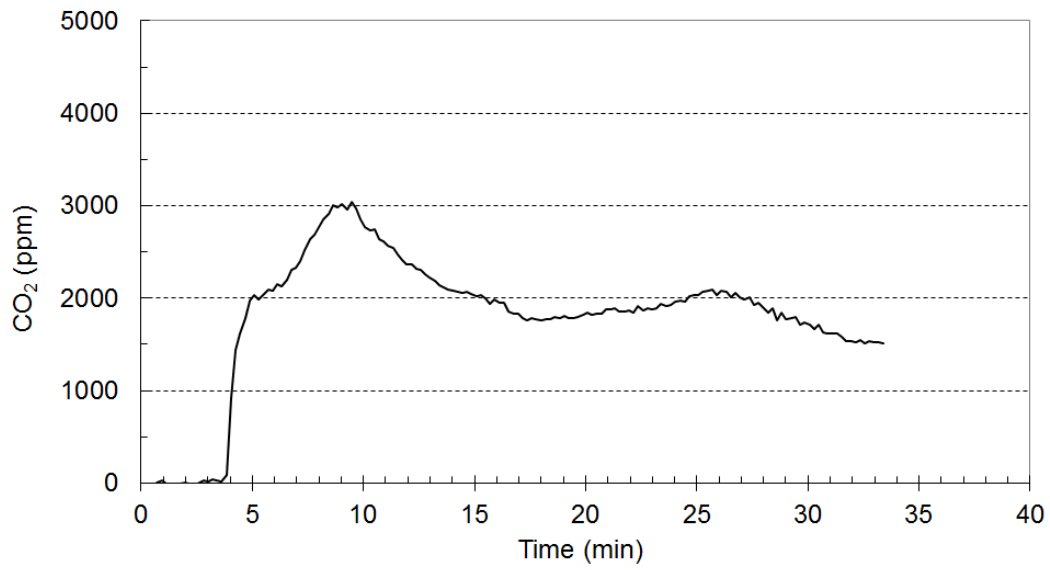

Figure 13 Concentration of CO₂ measured by FTIR in Test 4.

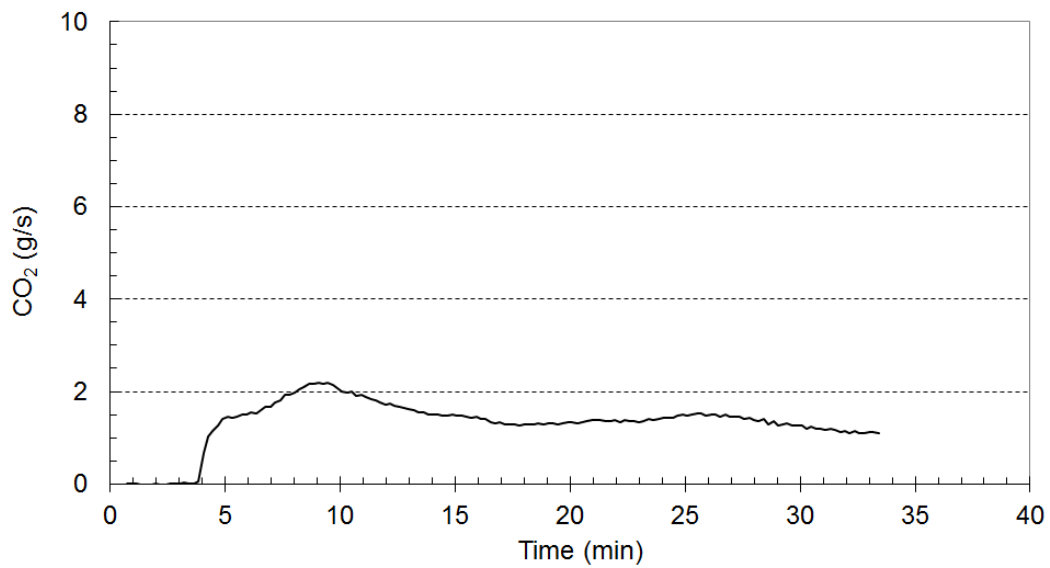

Figure 14 Production rate of CO₂ measured by FTIR in Test 4.

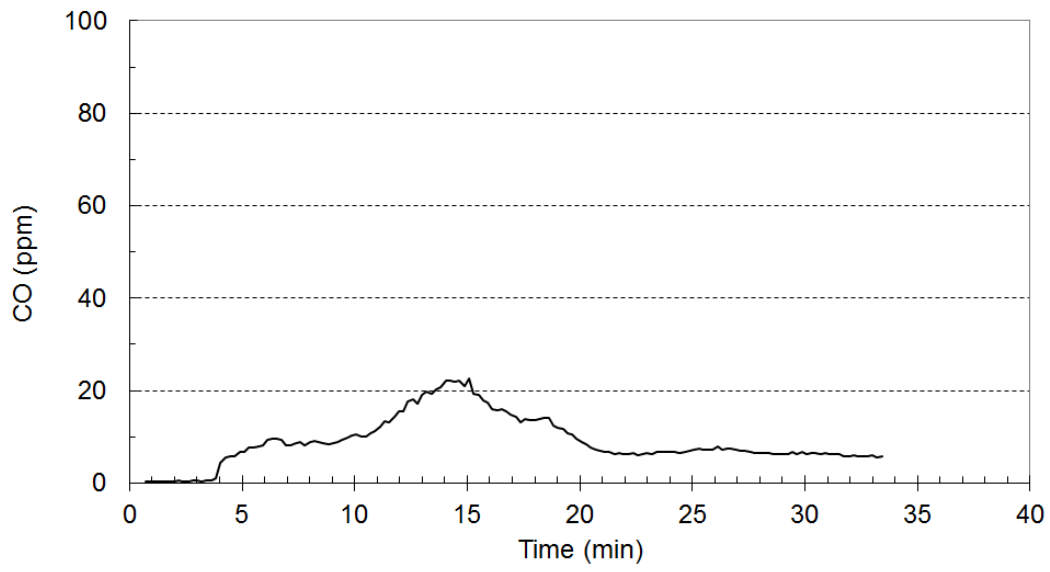

Figure 15 Concentration of CO measured by FTIR in Test 4.

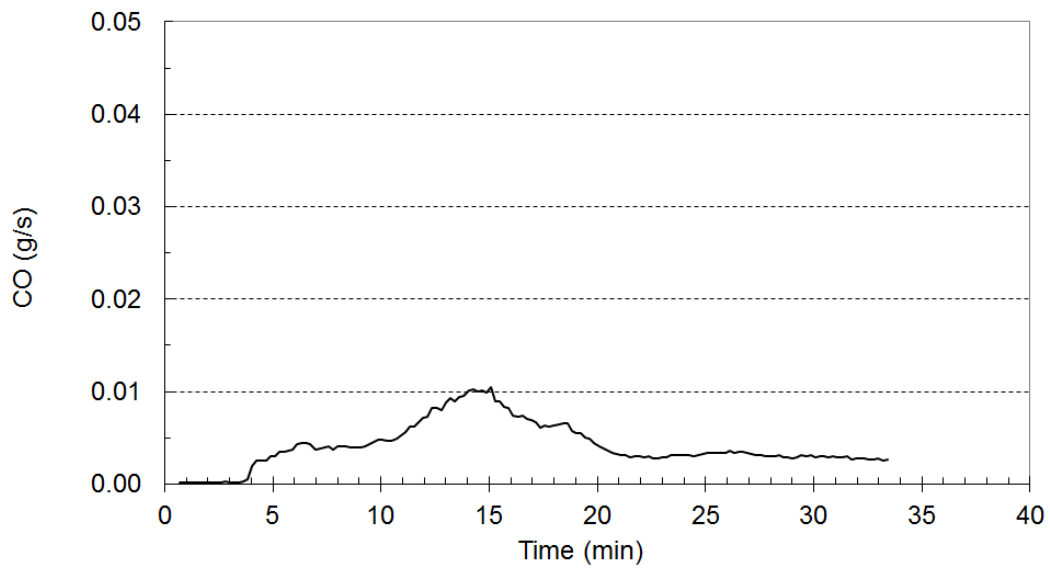

Figure 16 Production rate of CO measured by FTIR in Test 4.

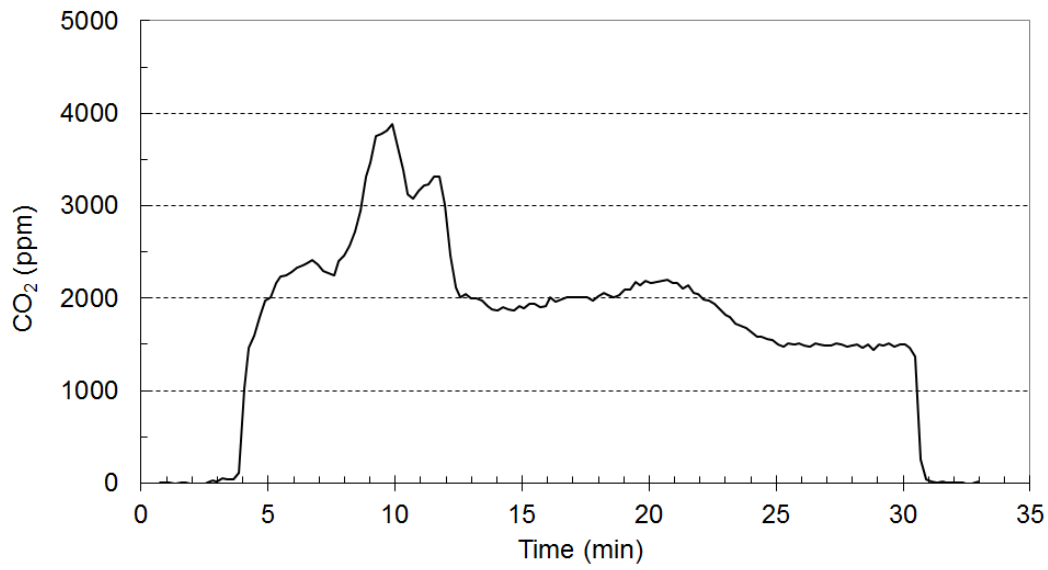

Figure 17 Concentration of CO₂ measured by FTIR in Test 5.

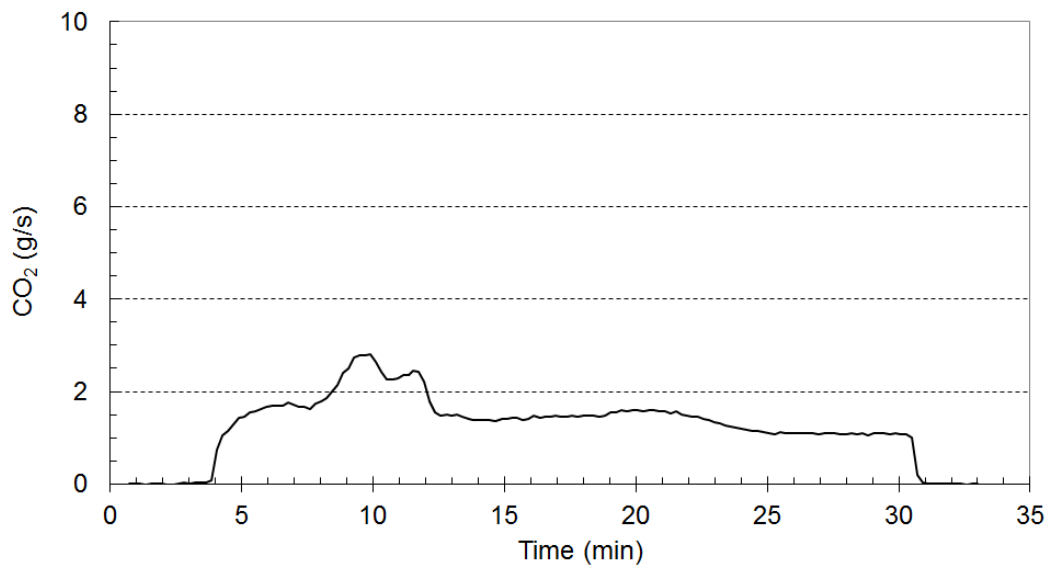

Figure 18 Production rate of CO₂ measured by FTIR in Test 5.

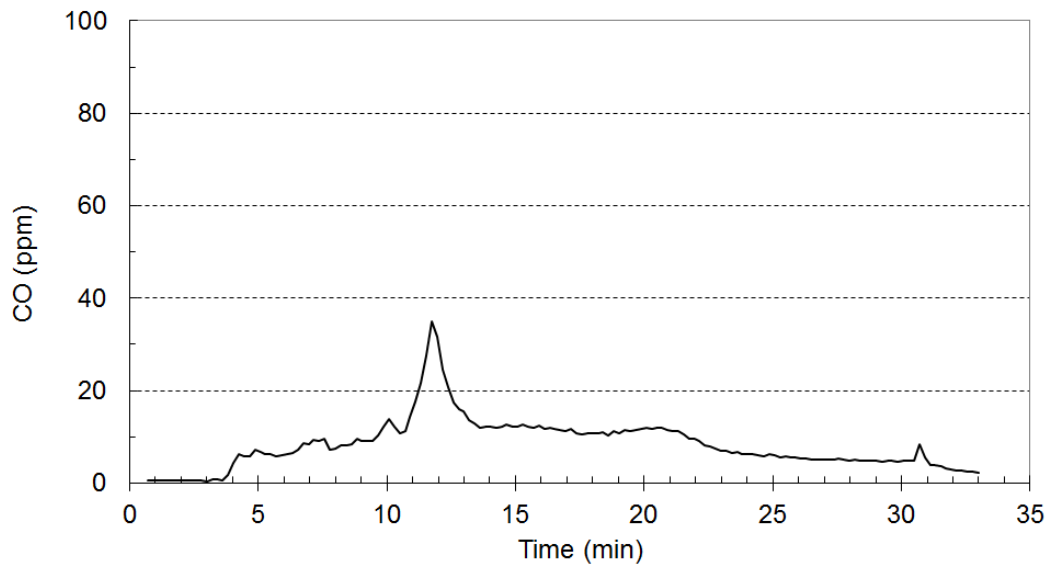

Figure 19 Concentration of CO measured by FTIR in Test 5.

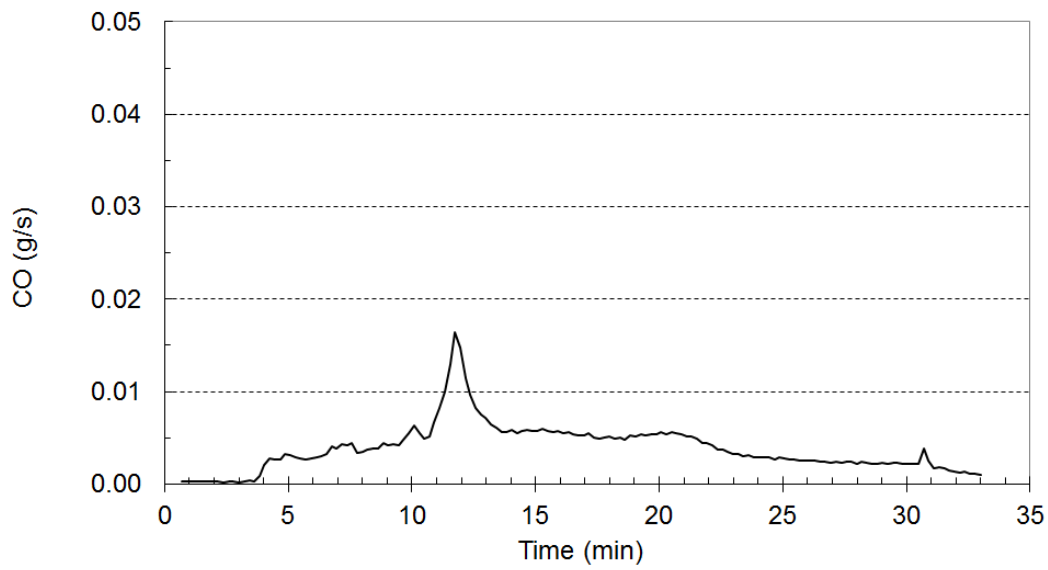

Figure 20 Production rate of CO measured by FTIR in Test 5.

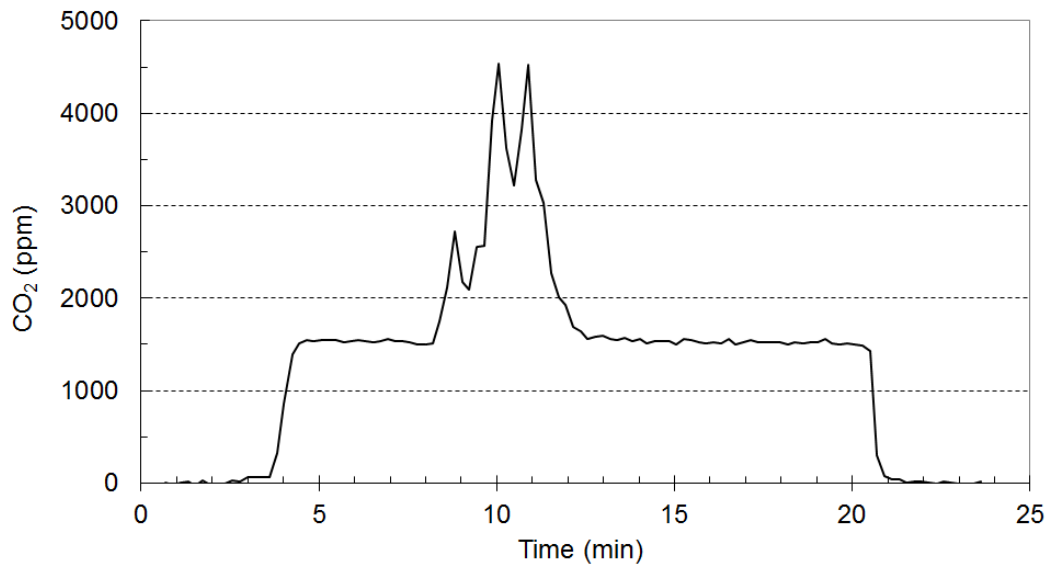

Figure 21 Concentration of CO₂ measured by FTIR in Test 6.

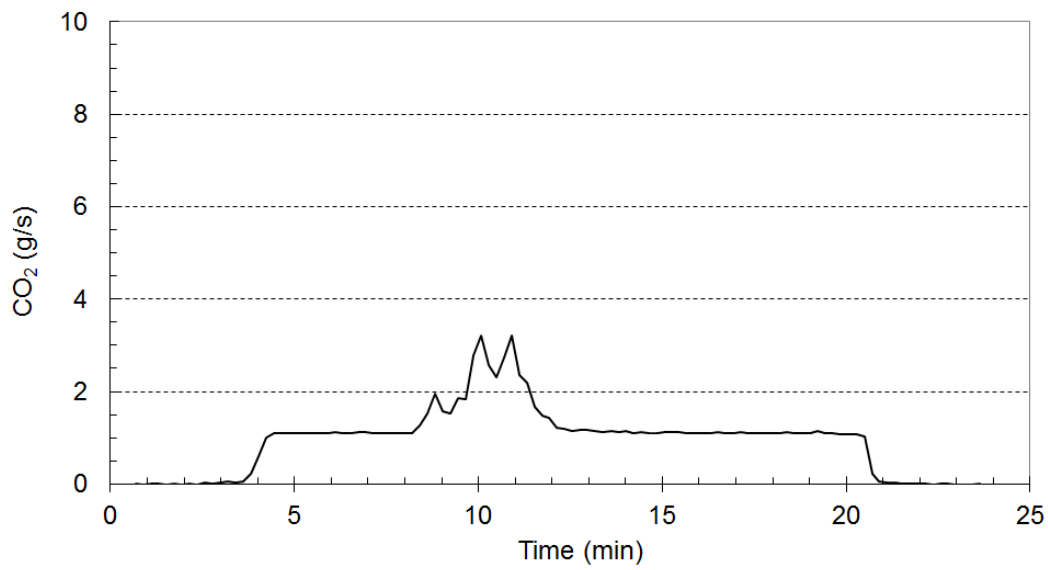

Figure 22 Production rate of CO₂ measured by FTIR in Test 6.

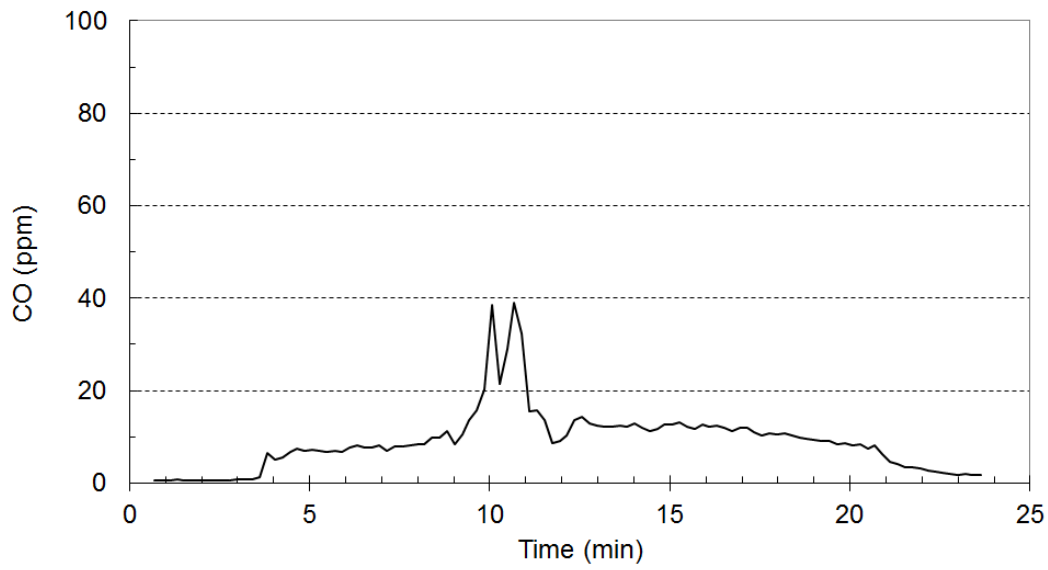

Figure 23 Concentration of CO measured by FTIR in Test 6.

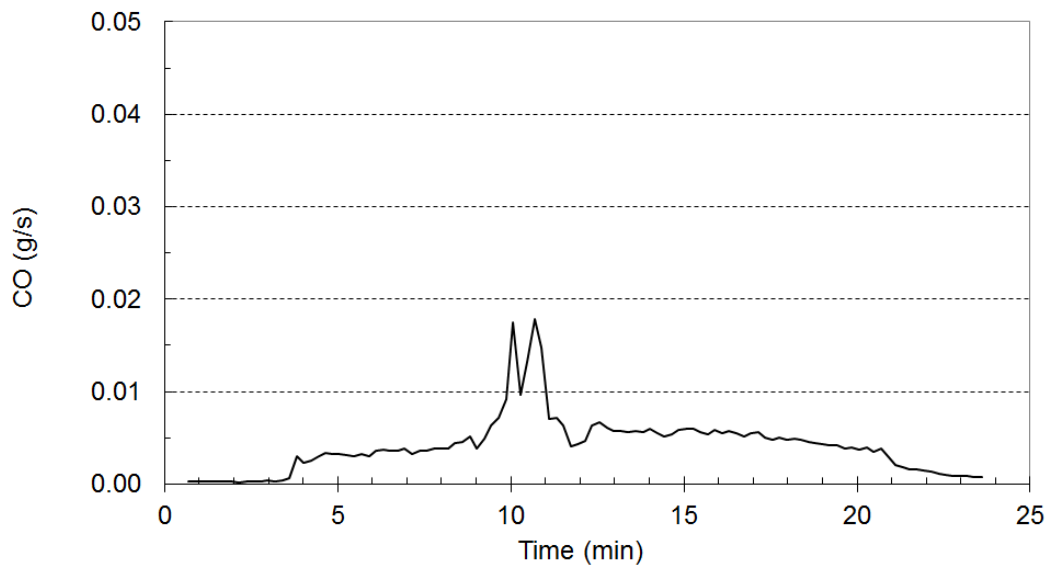

Figure 24 Production rate of CO measured by FTIR in Test 6.

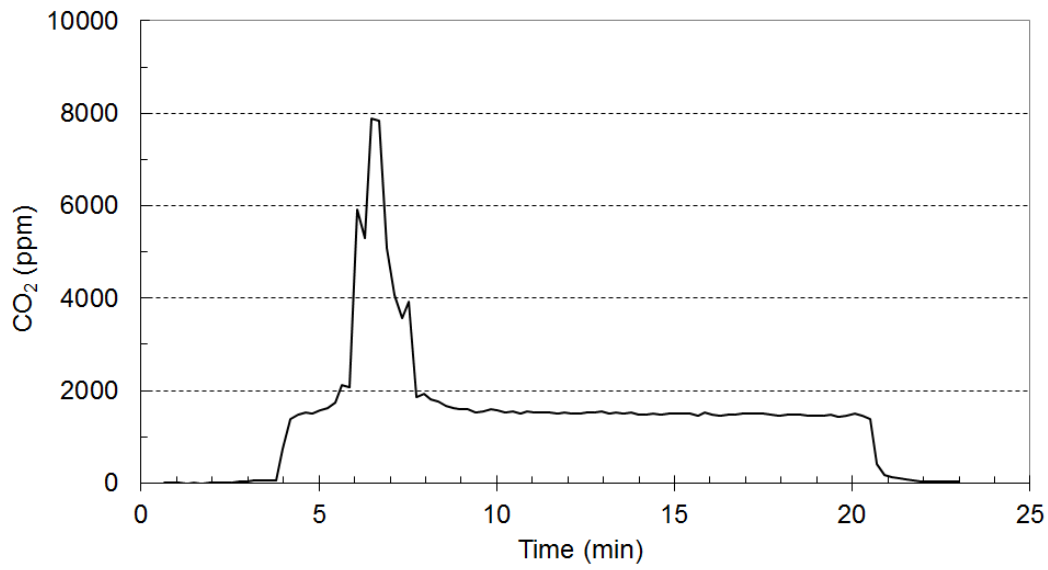

Figure 25 Concentration of CO₂ measured by FTIR in Test 7.

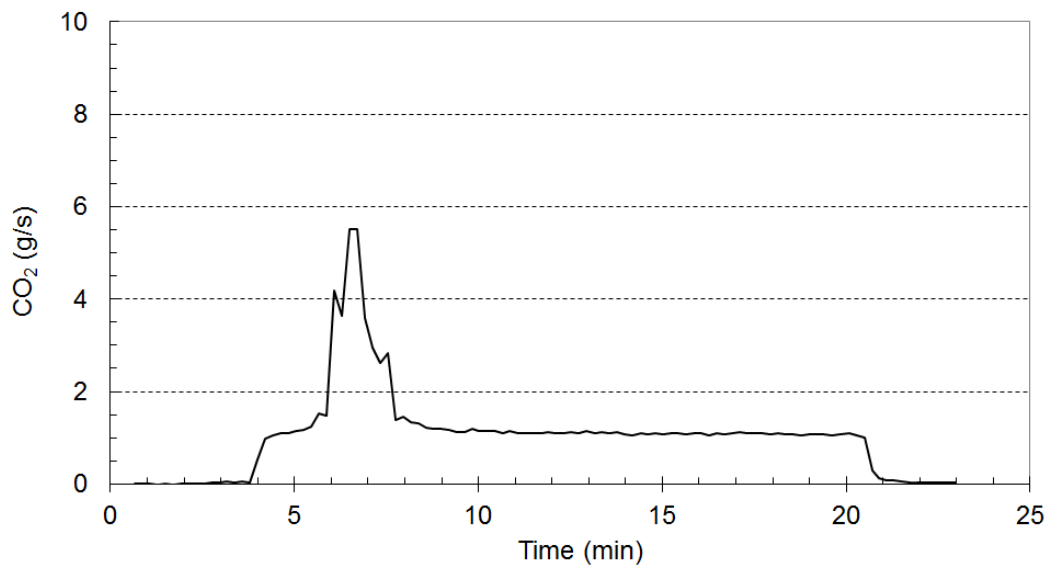

Figure 26 Production rate of CO₂ measured by FTIR in Test 7.

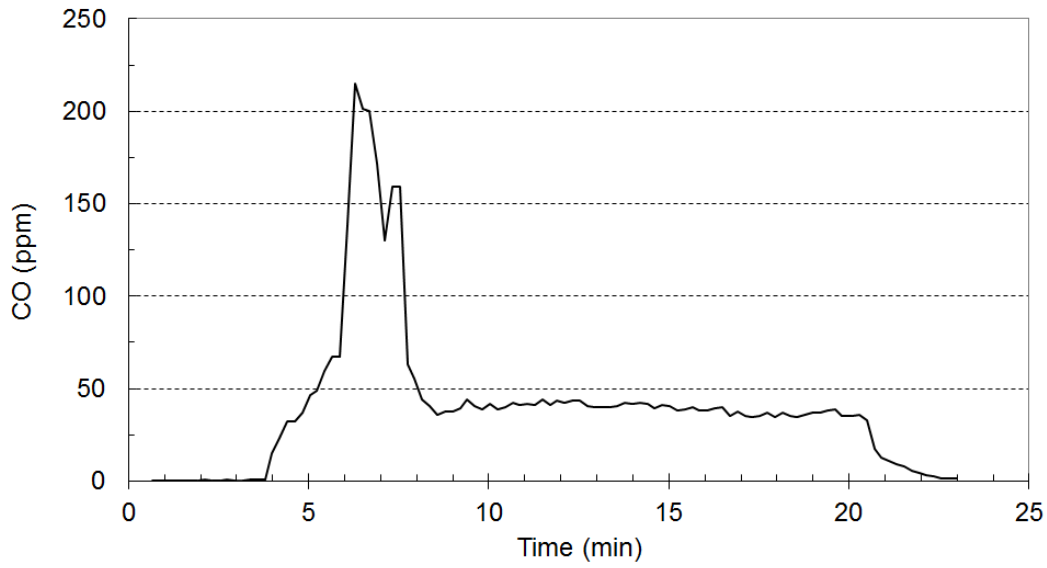

Figure 27 Concentration of CO measured by FTIR in Test 7.

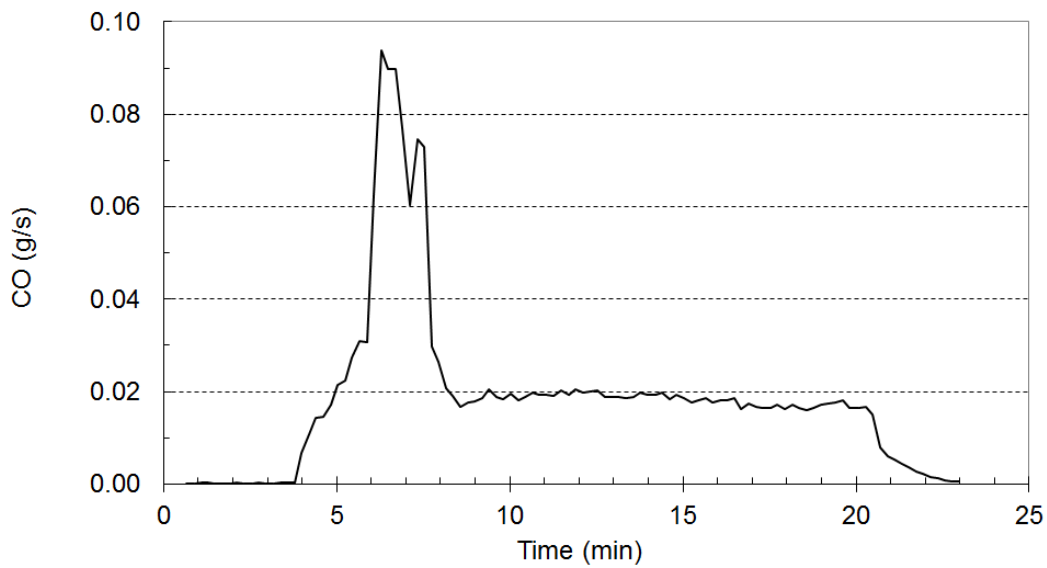

Figure 28 Production rate of CO measured by FTIR in Test 7.

Table 1 Results of CO₂ analysis with FTIR from test 1-5.

Test no	Total amounts with burner contribution subtracted (g)	Total yields (mg/g)
1	599	488
2	610	496
3	646	525
4	553	450
5	653	532

Table 2 Results of CO analysis with FTIR from test 1-5.

Test no	Max production rate (g/s)	Total amounts (g)	Total yields (mg/g)
1	0.041	6.0	4.9
2	0.038	6.2	5.0
3	0.050	6.7	5.4
4	0.011	8.4	6.8
5	0.016	7.6	6.2

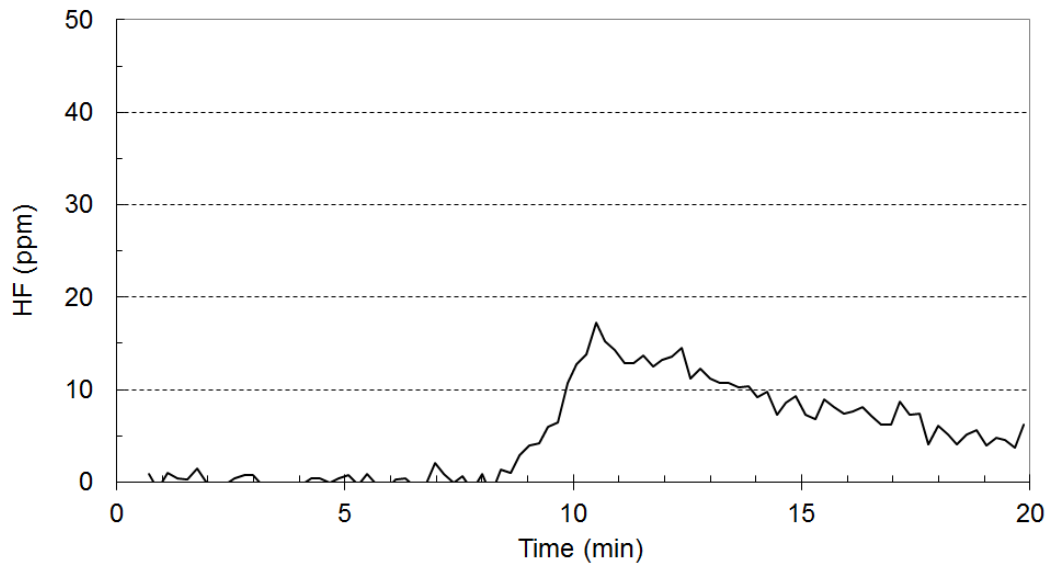

Figure 29 Concentration of HF measured by FTIR in Test 1.

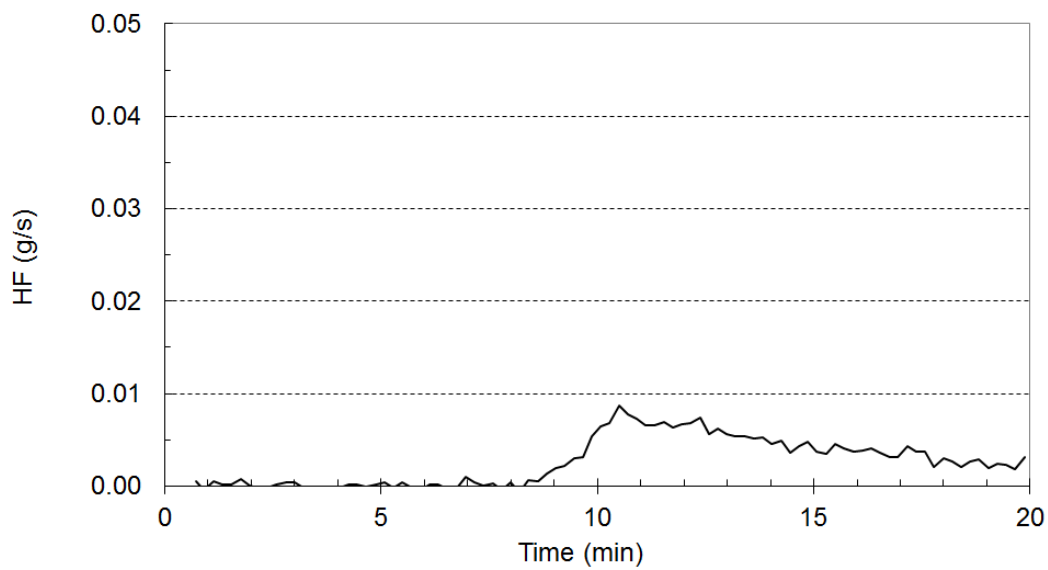

Figure 30 Production rate of HF measured by FTIR in Test 1.

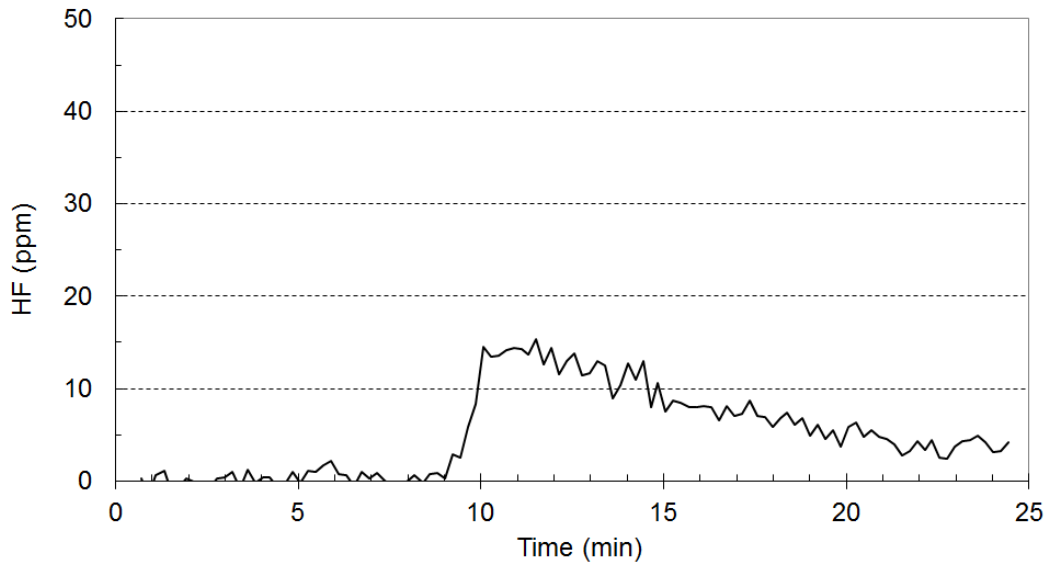

Figure 31 Concentration of HF measured by FTIR in Test 2.

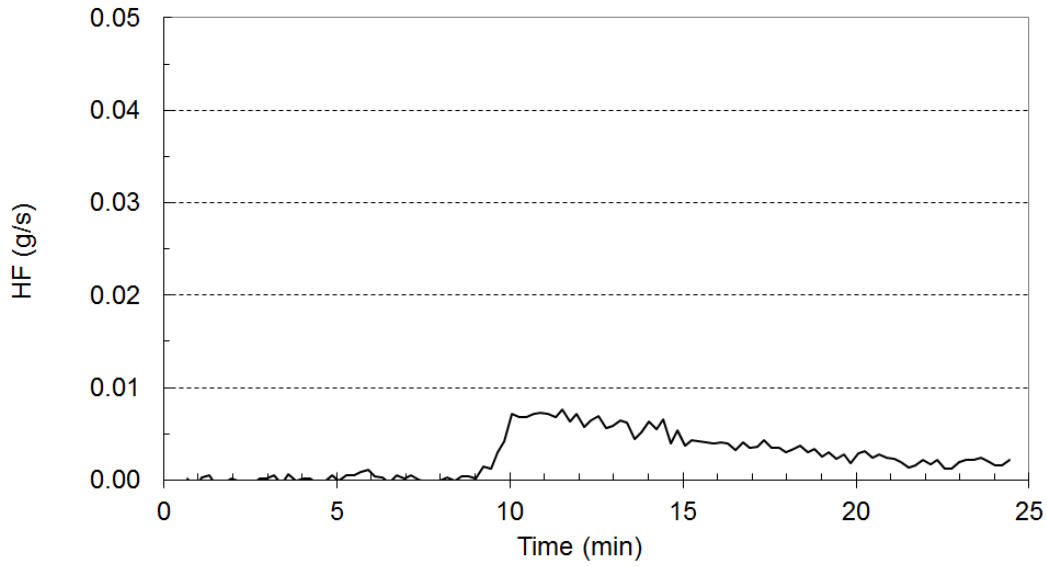

Figure 32 Production rate of HF measured by FTIR in Test 2.

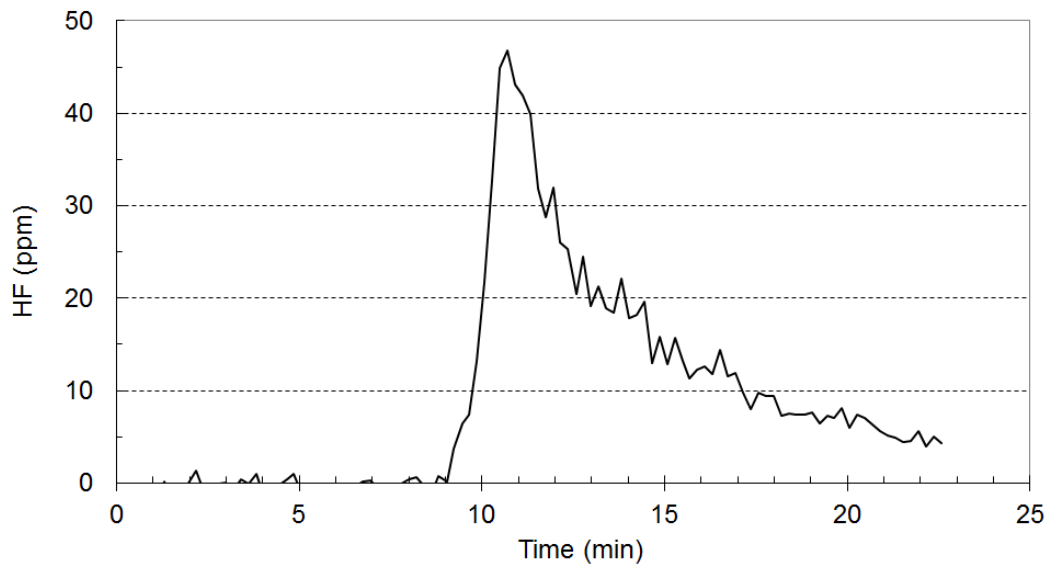

Figure 33 Concentration of HF measured by FTIR in Test 3.

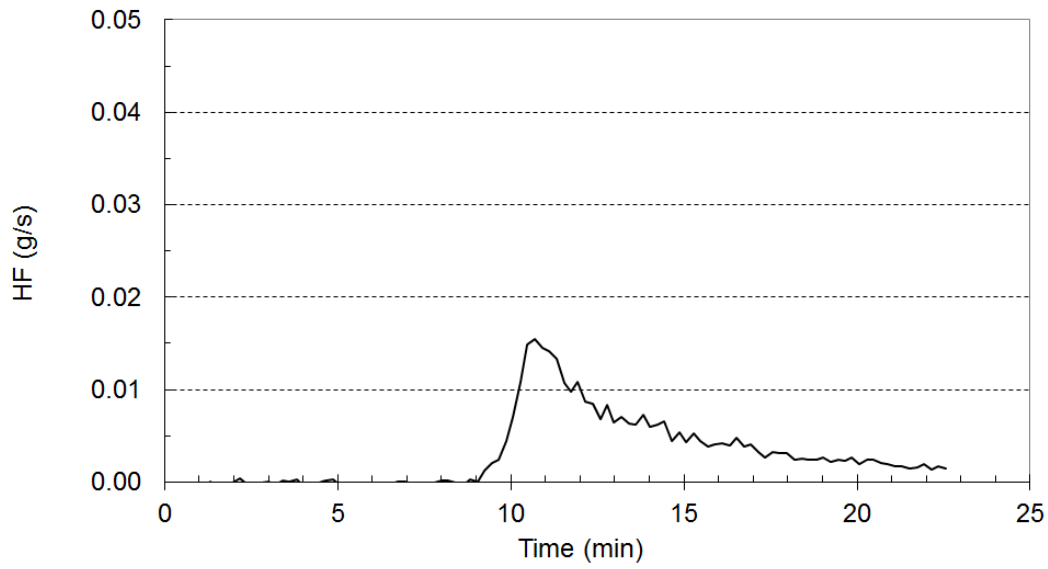

Figure 34 Production rate of HF measured by FTIR in Test 3.

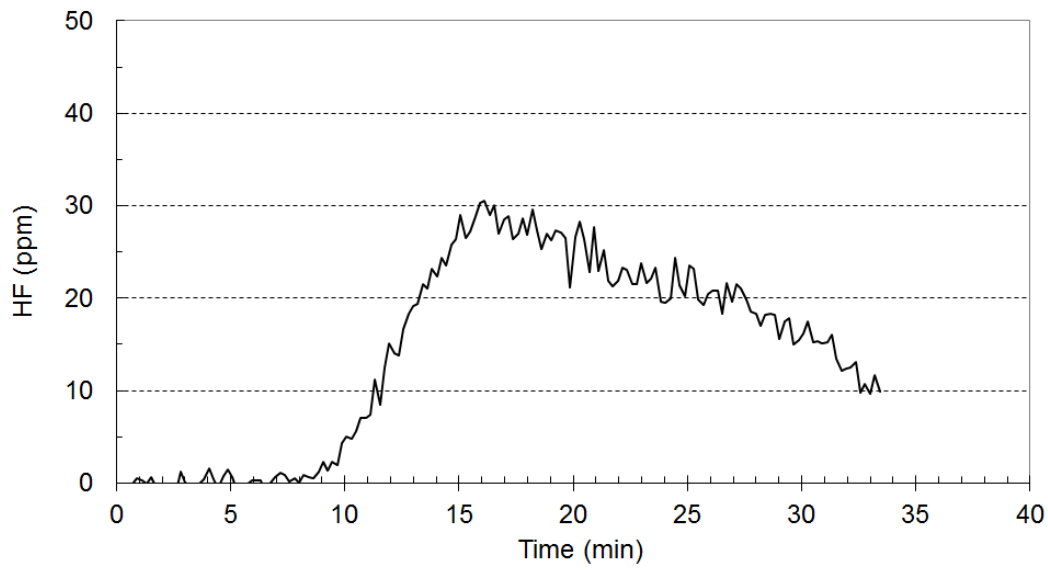

Figure 35 Concentration of HF measured by FTIR in Test 4.

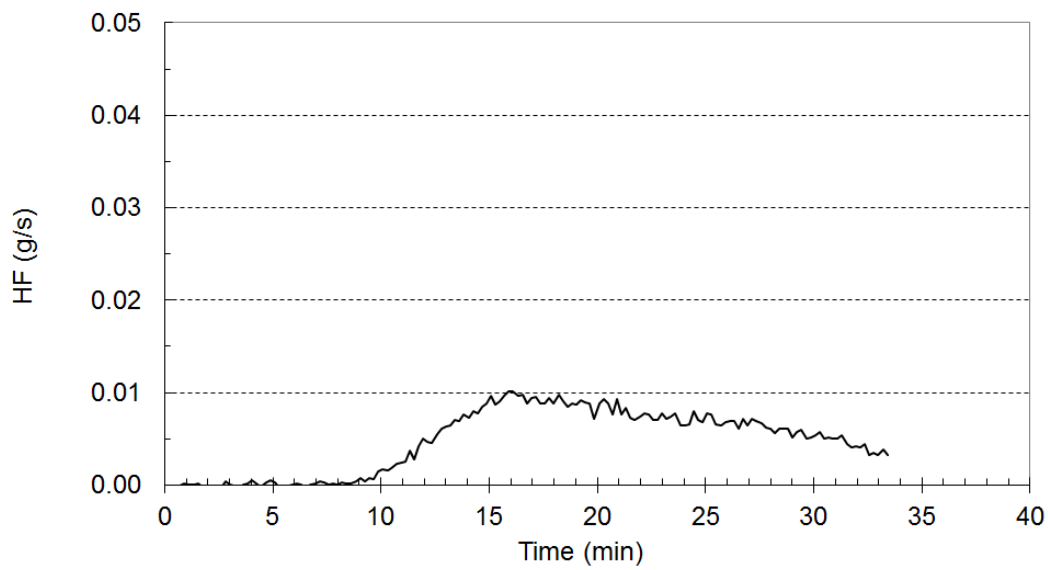

Figure 36 Production rate of HF measured by FTIR in Test 4.

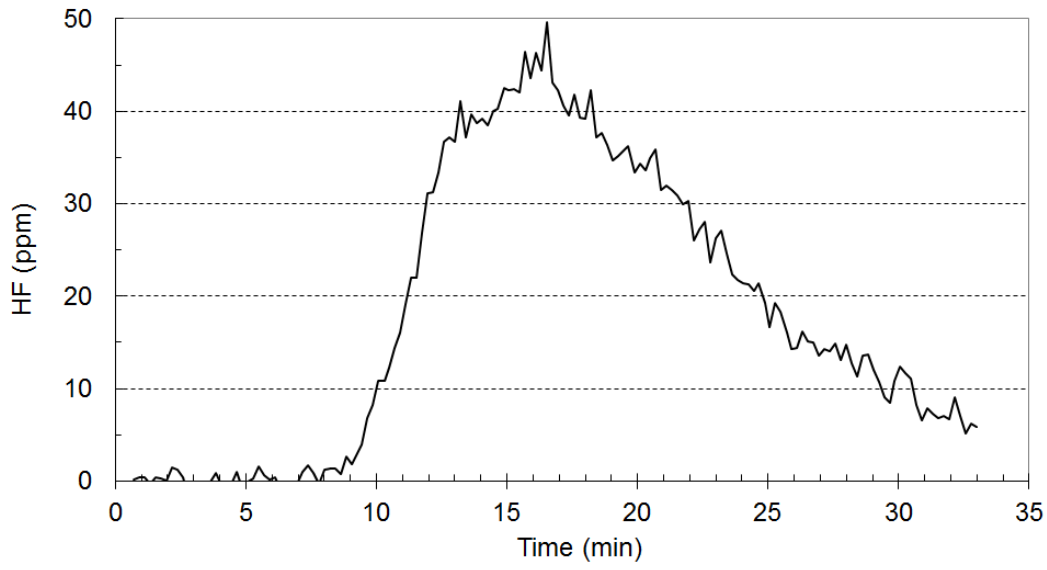

Figure 37 Concentration of HF measured by FTIR in Test 5.

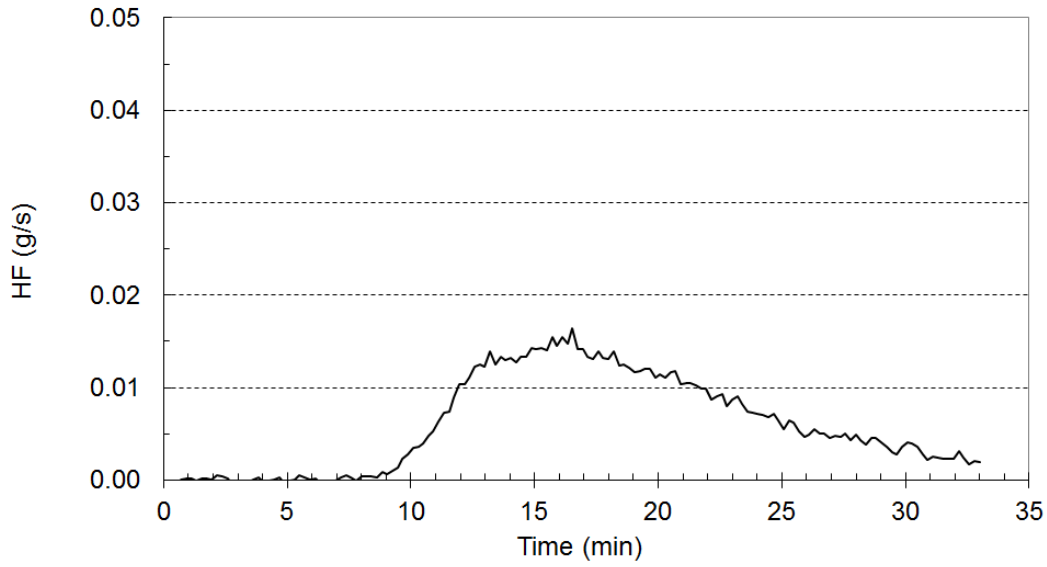

Figure 38 Production rate of HF measured by FTIR in Test 5.

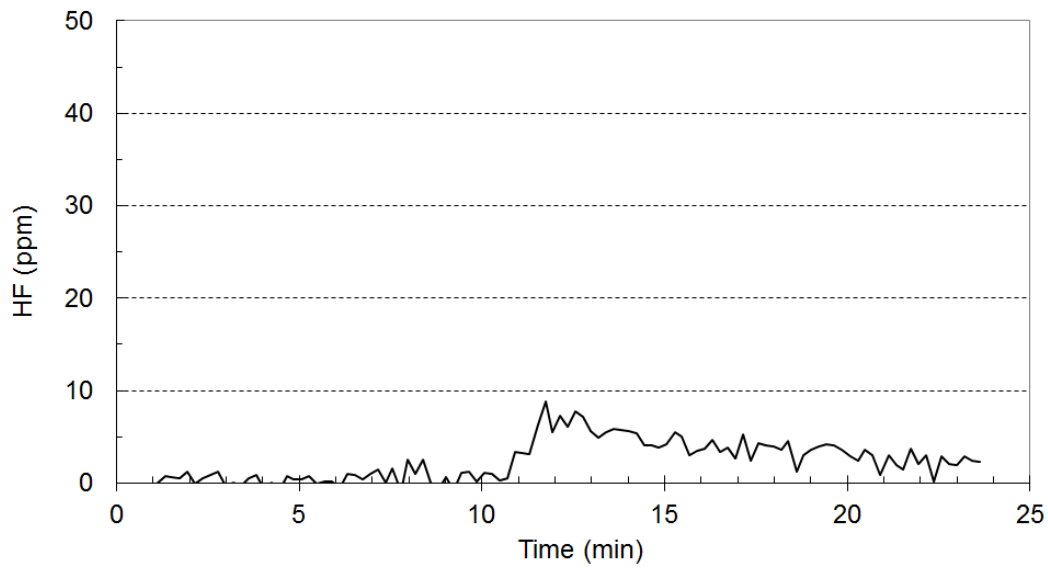

Figure 39 Concentration of HF measured by FTIR in Test 6.

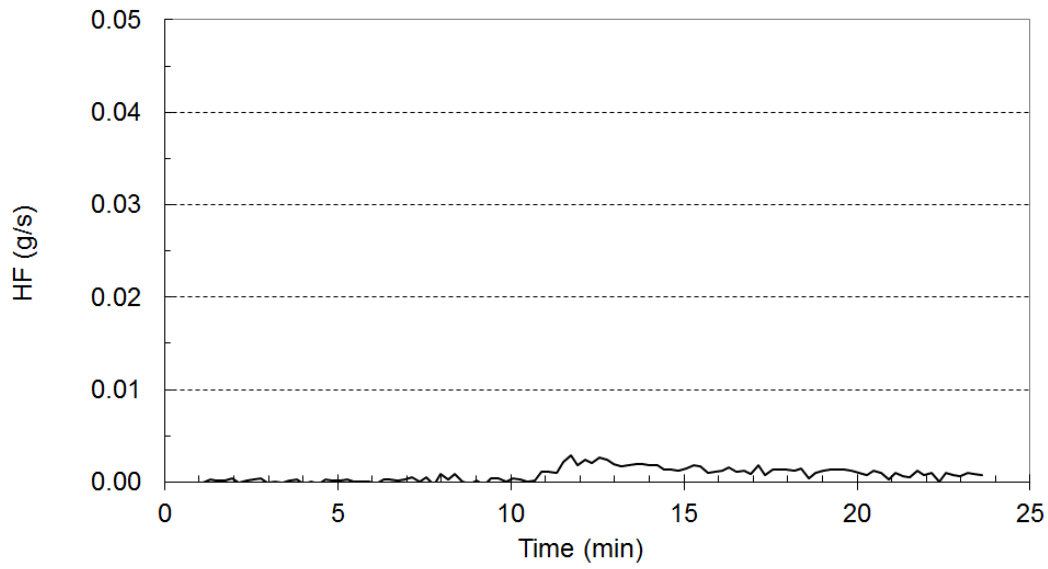

Figure 40 Production rate of HF measured by FTIR in Test 6.

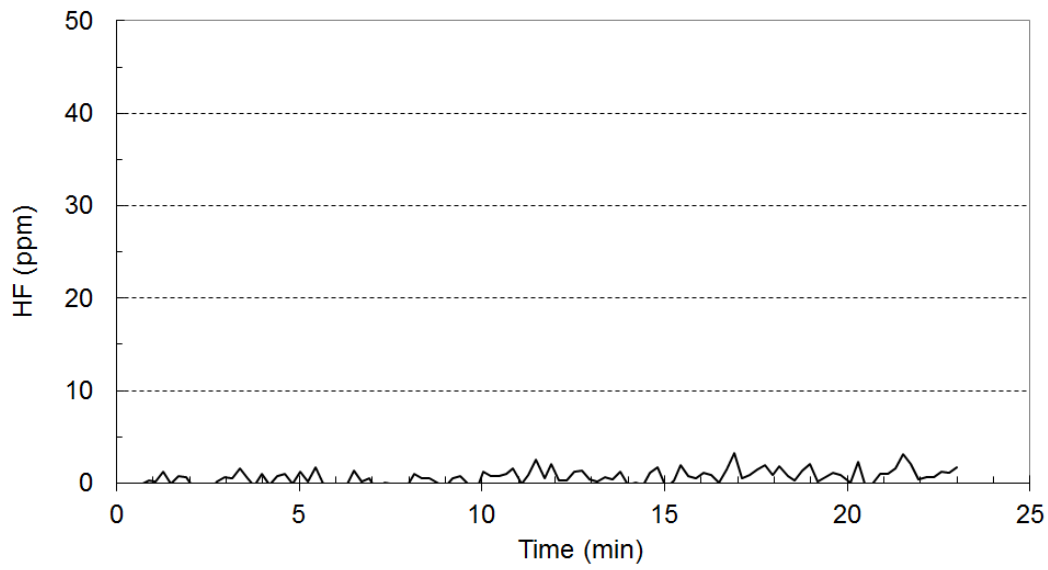

Figure 41 Concentration of HF measured by FTIR in Test 7.

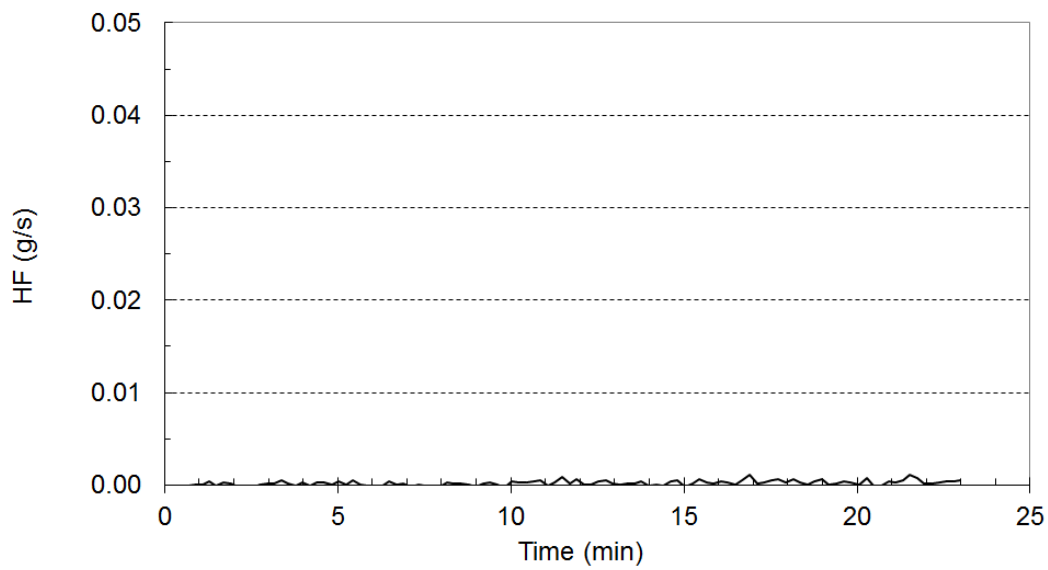

Figure 42 Production rate of HF measured by FTIR in Test 7.

Appendix C Photos from cell experiments



Figure 1 Burner during blank test 1



Figure 2 Typical outburst test 1



Figure 3 Later stage of fire Test 1



Figure 4 Outburst example test 2



Figure 5 Close up of test 2.



Figure 6 After test 2



Figure 7 Applying water test 3



Figure 8 Applying water test 3



Figure 9 Applying water test 3

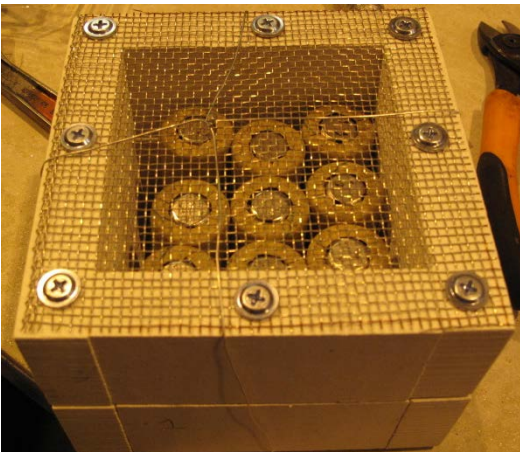

Figure 10 Cells for test 6 in their test container



Figure 11 Test 6



Figure 12 Test 6

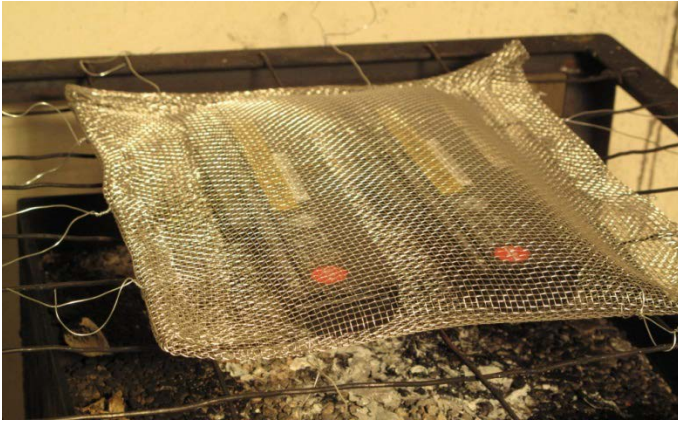

Figure 13 Laptop cells in their container placed on burner before test 7



Figure 14 Outburst example test 7



Figure 15 Outburst example test 7



Figure 16 Outburst example test 7

SP Technical Research Institute of Sweden

Our work is concentrated on innovation and the development of value-adding technology. Using Sweden's most extensive and advanced resources for technical evaluation, measurement technology, research and development, we make an important contribution to the competitiveness and sustainable development of industry. Research is carried out in close conjunction with universities and institutes of technology, to the benefit of a customer base of about 9000 organisations, ranging from start-up companies developing new technologies or new ideas to international groups.

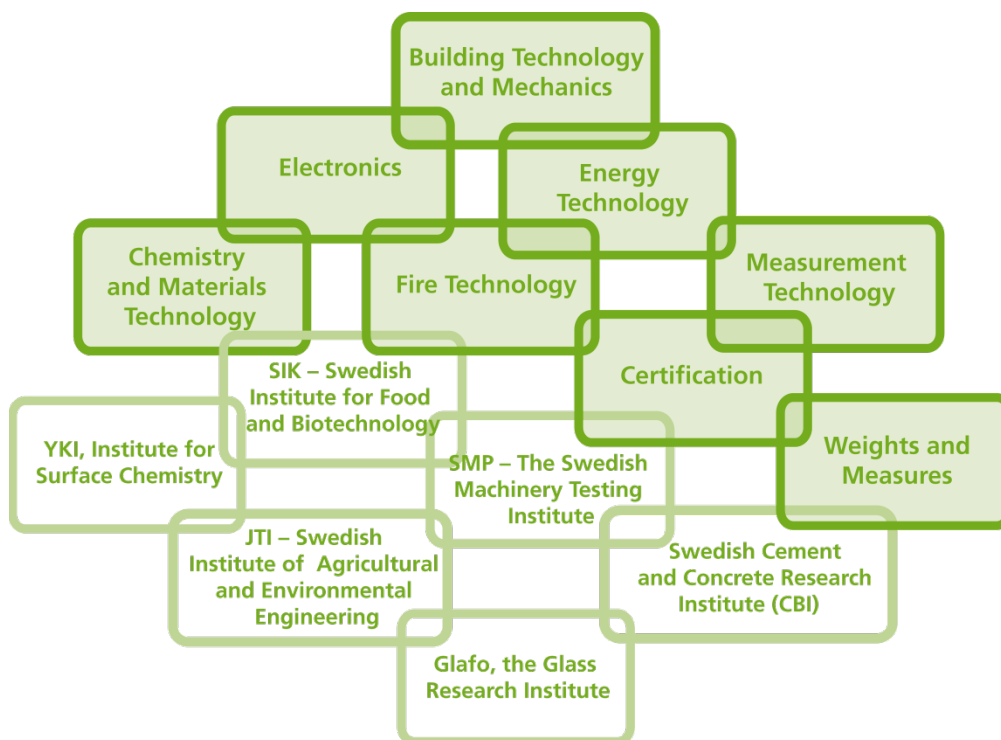

SP Technical Research Institute of Sweden

Box 857, SE-501 15 BORÅS, SWEDEN

Telephone: +46 10 516 50 00, Telefax: +46 33 13 55 02

E-mail: info@sp.se, Internet: www.sp.se

www.sp.se

Fire Technology

SP Report 2013:15

ISBN 978-91-87461-00-2

ISSN 0284-5172

More information about publications published by SP: www.sp.se/publ